



# KEY COMPUTER SYSTEMS

BY SUSHIL BHUDIA

EURO HI-TECH PHOTOGRAPHIC  
SERVICES LTD

Copy Right All Rights Reserved Since  
1991

# KEY COMPUTER SYSTEMS

*BY SUSHIL BHUDIA*



I would here by like to thank the British Government Organisations and the GP association UK for supporting my research and calibration of this key computer system with Euro Hi-Tech Photographic Services Ltd. With out there support it would be impossible to spend time developing this project for the UK free market and International Market Place.

I hope one day we can improve Human IT Capital Levels and reduce inequity and deprivation amongst individuals and strive for better richer communities and there after greater opportunity for all.





General enquiry details  
IPO UK -Concept House  
Cardiff Road  
Newport  
South Wales  
NP10 8QQ  
United Kingdom  
Email  
[information@ipo.gov.uk](mailto:information@ipo.gov.uk)

**EURO HI –TECH PHOTOGRAPHIC SERVICES LTD**

**COMPUTER INTELLECTUAL PATANT OFFICE FILE NUMBER: GB 2510034.8 FILED 23-06-25 ©**

**PAY BY KEY INTELLECTUAL PATANT OFFICE FILE NUMBER: GB 2510010.8 FILED 23-06-25 ©**

**FILED BY MR SUSHIL KARSAN BHUDIA**

[SUSHIL@EUROHITECH.COM](mailto:SUSHIL@EUROHITECH.COM)



**ALL RIGHTS RESERVED ©**

**MOBILE CAMERA COMPUTER KEY PROJECT BY EURO HI-TECH PHOTOGRAPHIC SERVICES LTD**

**ALL RIGHT SRESERVED (COPYRIGHT) ©**

**FULL MECHANIZATION & CUSTOMIZATION & MOBILITY OF THE COMPUTER KEY.**

FIGURE 1: STATE OF THE ART CAMERA MOBILE HAND SET DESIGN

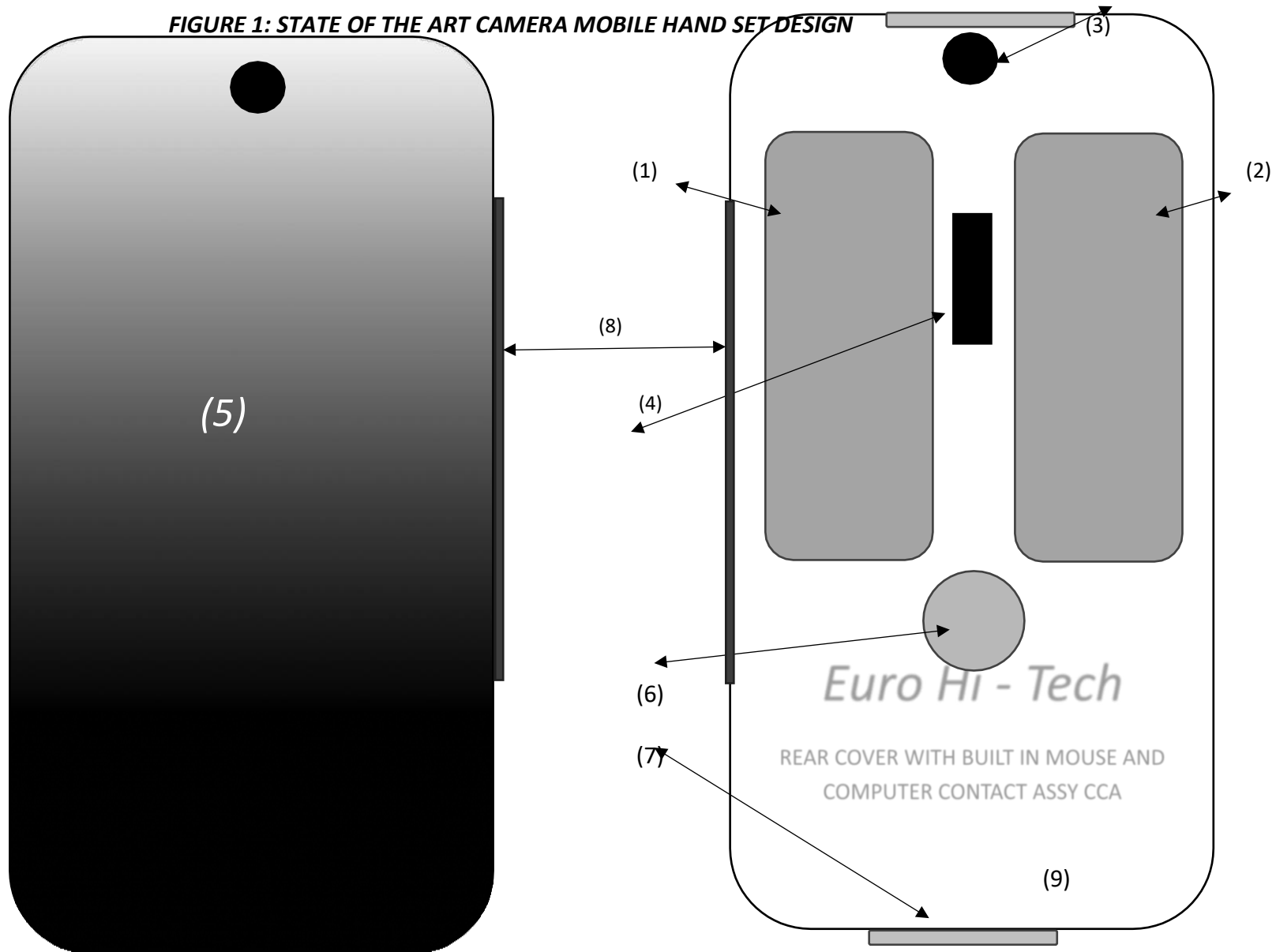

**FIGURE 1 KEY:**

- (1) LEFT MOUSE BUTTON**
- (2) RIGHT MOUSE BUTTON**
- (3) BUILT IN CAMERA**
- (4) DIAL ASSEMBLY**
- (5) FRONT LCD PANEL**
- (6) ROLLABLE MARBEL MOUSE/ MULITCONTROLLER JOYSTICK**
- (7) COMPUTER CONTACT ASSEMBLIES**
- (8) FOLDING HINGE UNIT DOUBLE SIDED LCD /BENDABLE LCD**
- (9) REAR COVER WITH BUILT IN MOUSE AND COMPUTER CONTACT ASSEMBLIES**

**FIGURE 2: STATE OF THE ART COMPUTER CAMERA DESIGN**

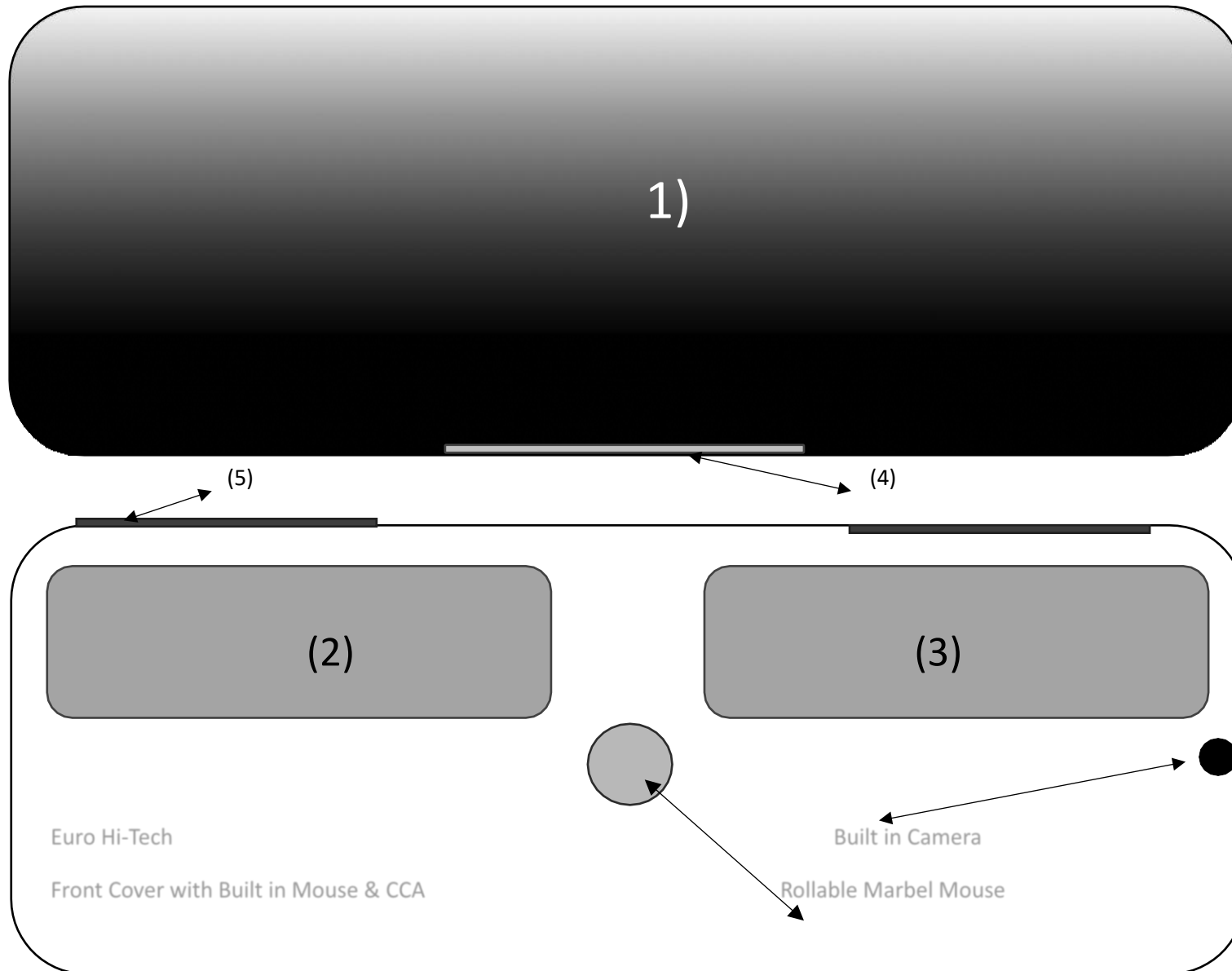

**FIGURE 2: KEY:**

**(1) Front COVER WITH BENDABLE LCD**

**(2)Left MOUSE BUTTON**

**(3)RIGHT MOUSE BUTTON**

**(4)HING UNIT**

**(5)COMPUTER CONTACT ASSEMBLIES X 2 ( CONTACT ASSY)**

FIGURE 3: PORTABLE CAMERA MOBILE COMPUTER

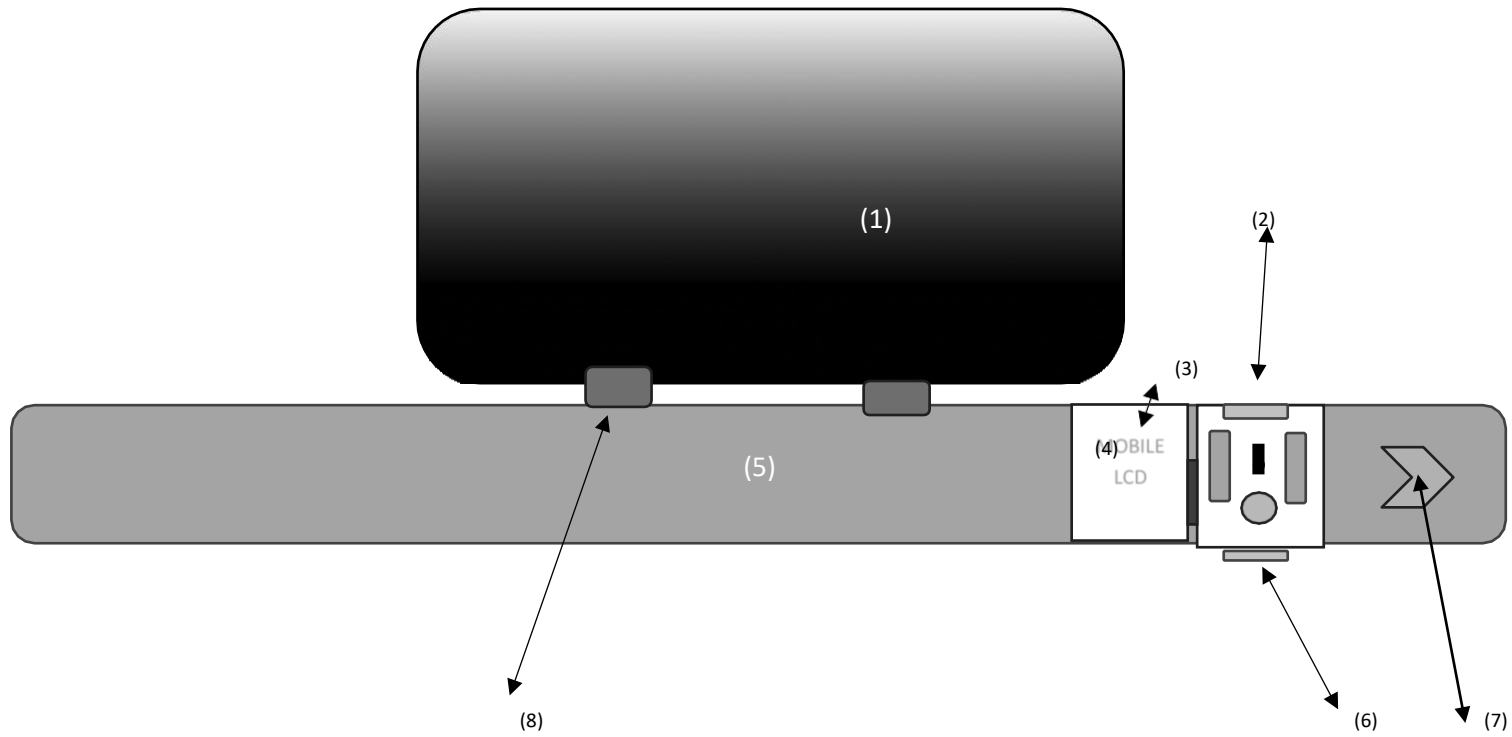

**FIGURE 3: KEY**

- (1) LARGER TFT SCREEN –UPPER LCD PANEL –COMPUTER MONITOR SCREEN**
- (2) REAR COVER OF MOBILE PHONE VERTICLE-WITH BUILT IN MOUSE AND DIAL AND MULTICONTROLLER JOYSTICK**
- (3) FRONT OF MOBILE PHONE**
- (4) FRONT OF MOBILE WITH LCD PANEL**
- (5) KEY BOARD**
- (6) COMPUTER CONTACT ASSEMBLIES**
- (7) RELEASE MECHANISM TO CONNECT AND DISCONNECT THE HAND SET.**
- (8) HINGE UNIT**

FIGURE 4. NETWORK DRIVES WITH LOCATIONS

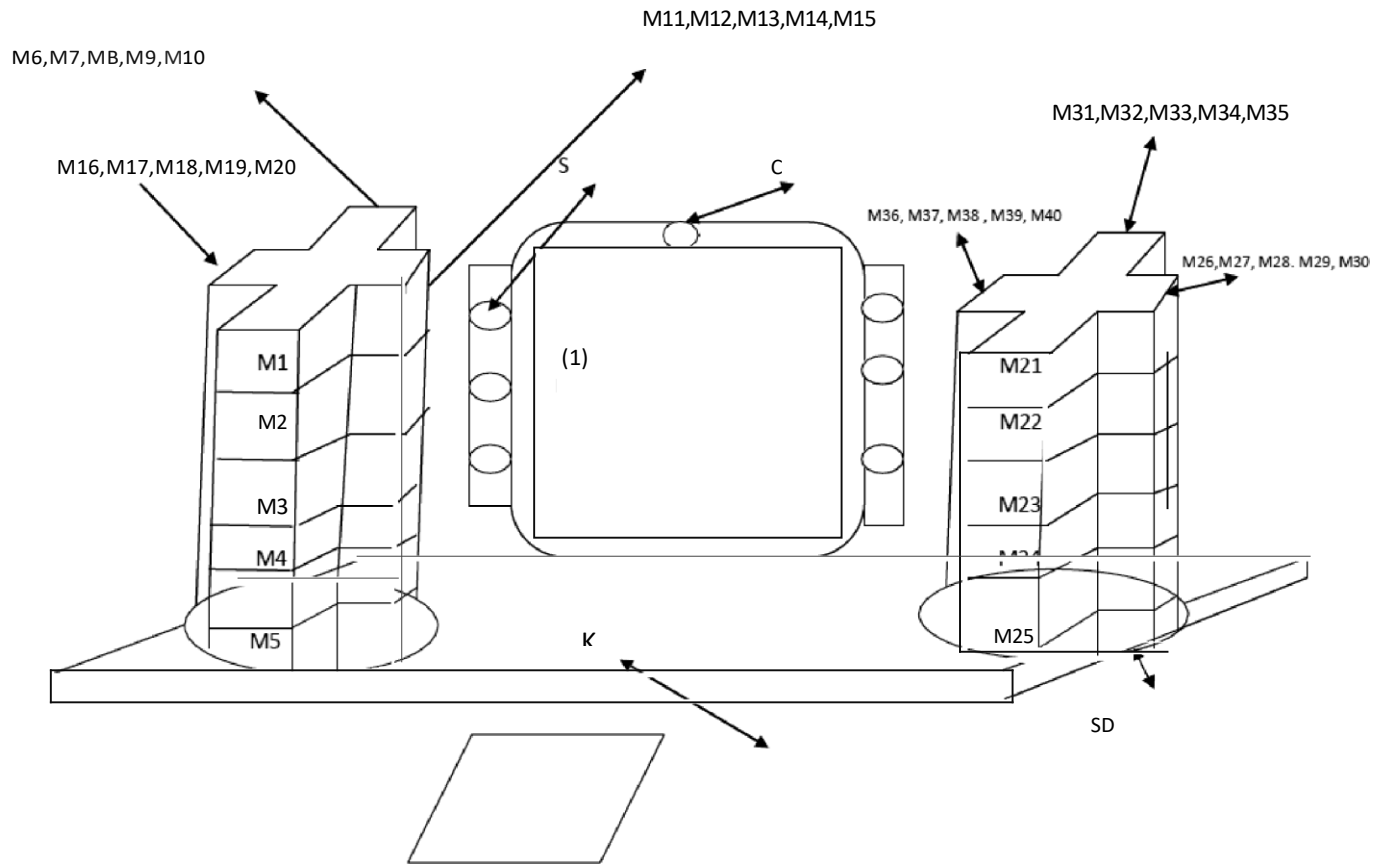

**FIGURE 4 : KEY:**

**(1) LARGER TFT SCREEN**

**M1 TO M40 = UPTO 40 MOBILE UNITS ON A PLUS NETWORK SYSTEM**

**S = SPEAKER**

**C= CAMERA**

**K = KEYBOARD**

**SD = SPINNING DISKS**

**FIGURE 5: STACK SYSTEMS OF HAND SETS**

**MOBILE CAMERA PHONE STACK DRIVE SYSTEMS, THIS TRACKS MONEY SUPPLY AND NEW  
CONCEPT OF MUSICAL SYSTEMS REMIX (MS) A- SECURITY CONCEPT.**

**STACKS OF M (10N) ON THE KEYBOARD**

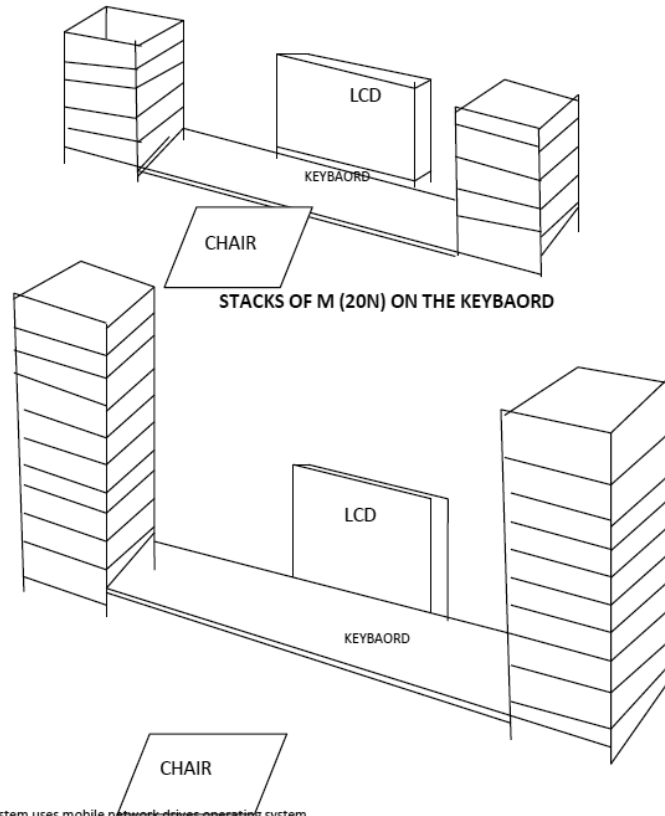

**STACKS OF M (20N) ON THE KEYBOARD**

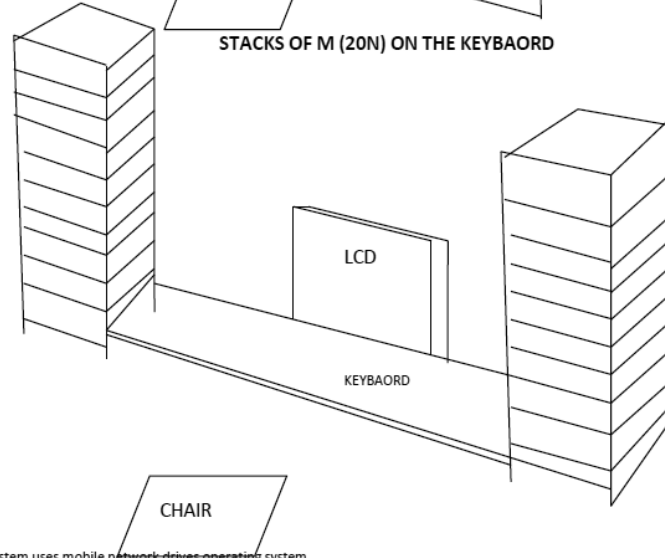

This system uses mobile network drives operating system.

**FIGURE 6: TABLE TOP COMPUTER WITH BUILT IN TFT SCREEN/KEYBOARD AND  
CONNECTED  
AND DISCONNECTED MOBILE CAMERA PHONE**

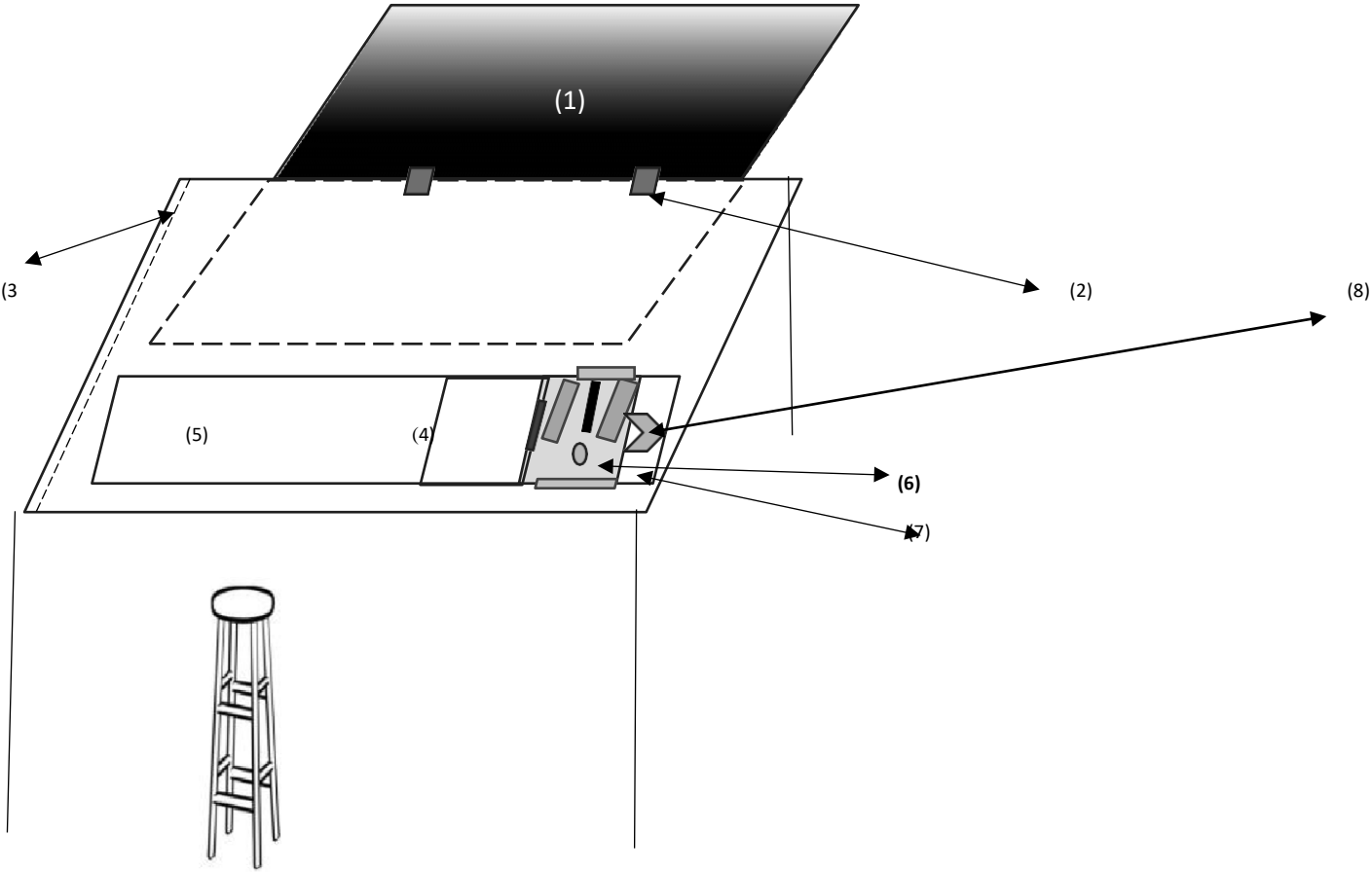

**FIGURE 6: KEY:**

**1) LARGER TFT SCREEN BUILT IN-LCD MONITOR**

**2) HINGE UNIT**

**3) SHUTTER UNIT FOR SECURITY**

**4) FRONT LCD PANEL**

**5) BUILT IN KEYBOARD**

**6) MOBILE CAMERA HAND SET I.E VERTICAL WITH FRONT AND FLIP MOUSE DESIGN**

**7) REAR COVER WITH BUILT IN MOUSE (FLIPP PRODUCTION)**

**(6) & (7) TO CONNECT AND DISCONNECT MOBILE PHONE HAND SET.**

**(8)-RELEASE MECHASIM FOR HAND SET ON KEYBOARD.**

**FIGURE 7: SECURITY CONCEPTS OF N SQUARED TO INFINITY USERS-EXPANIONARY-WITH DUPLICATION OF HANDSETS**

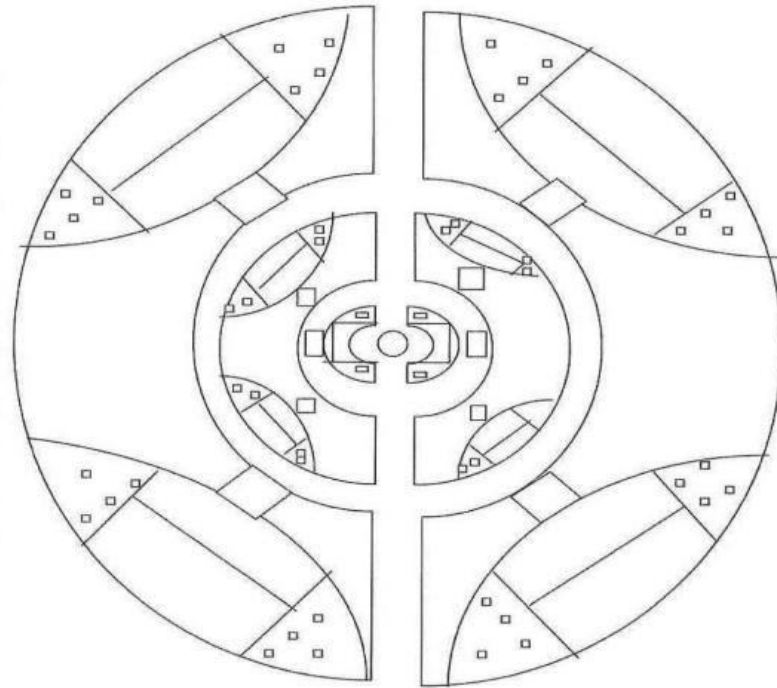

FIGURE 8:

CICULAR HUB FOR DYNAMIC ELECTRONIC EFFECIENCY & SECURITY PLATFORM

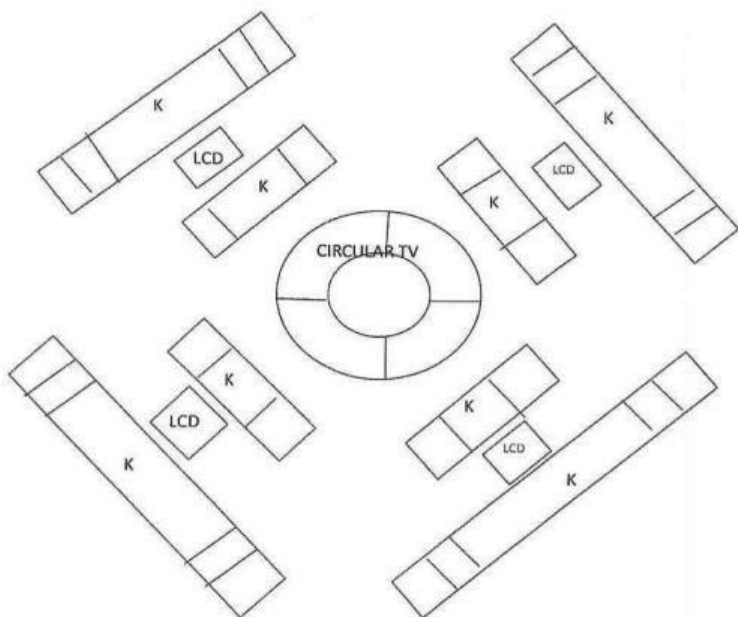

FIGURE 9: EDUCATIONAL CONTRACTS

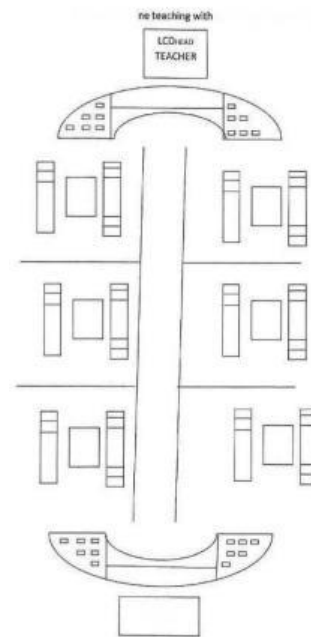

FIGURE 10: CYLINDER SCREEN 4WAY SYSTEM WHICH CAN BE EXPANDED TO INTARMIN

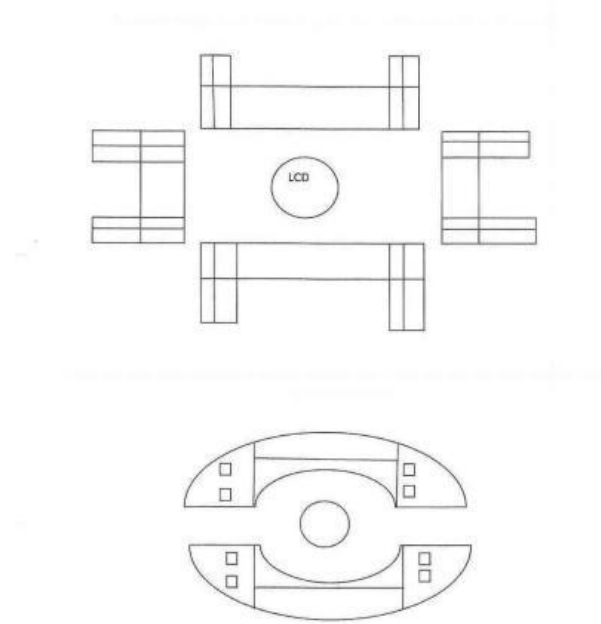

FIGURE 11: HETRONIAN SETUP N+2 INCREASING TO INTARMIN

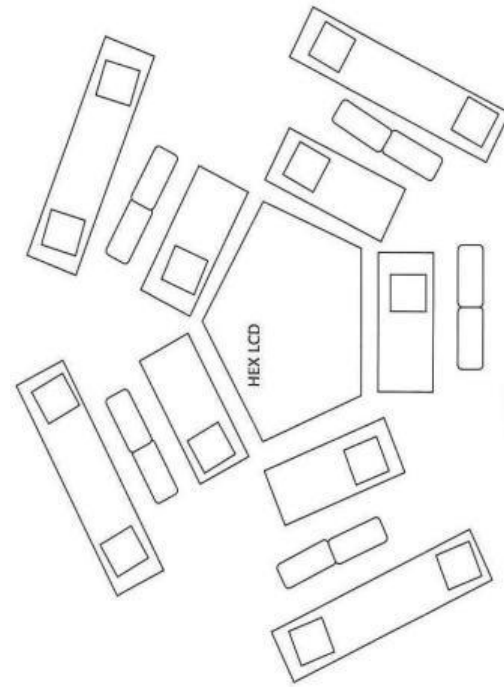
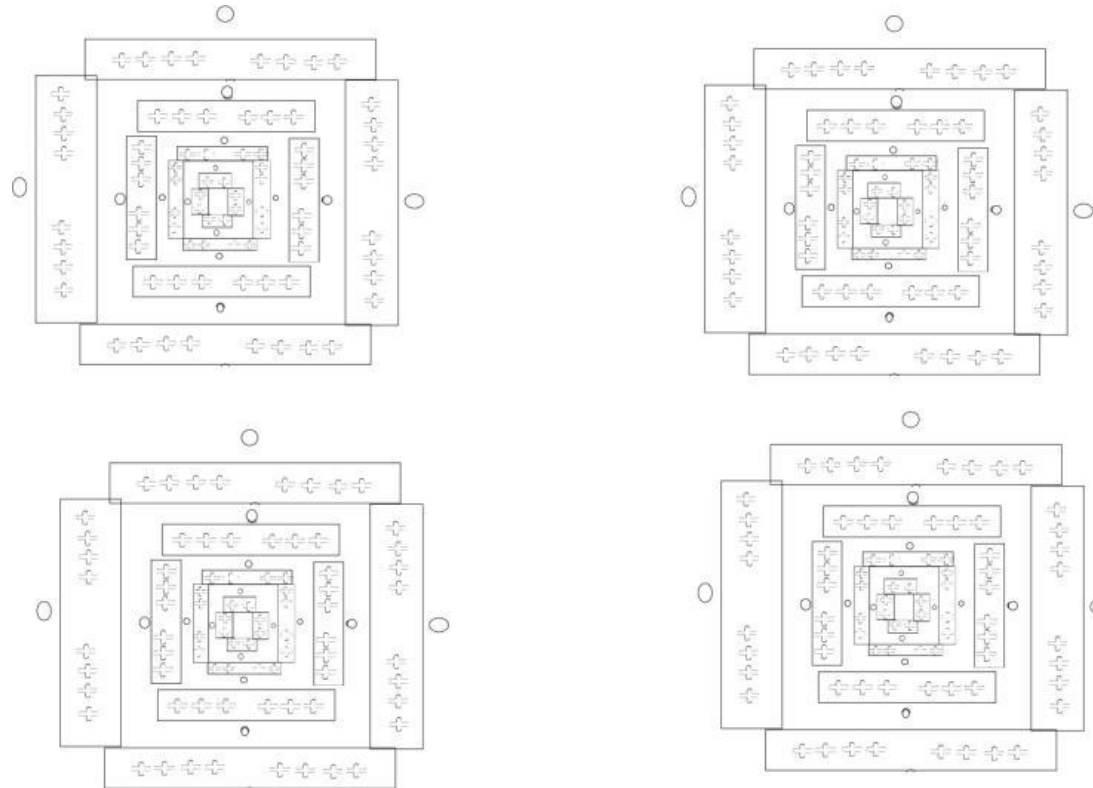
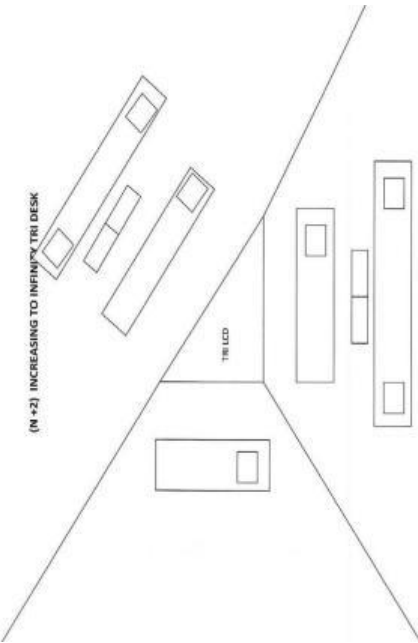

FIGURE 12: NETWORK **PLUS(+)** INFINITY DRIVES (N INCREASING BY N+4 TO INIFINITY)



**FIGURE 13: TRIANGULAR DESKSET UP 3WAY LCD SCREEN WHICH EXPANDS TO 2+N USERS ON EACH KEYBOARD.**



Firstly imagine a mobile phone or camera, well this can be docked in on to the keyboard. I.e a sleeping camera mobile on the right- or left-hand side of the keyboard. You can put a label/receipt printer on the keyboard or even a watch or even a calculator even a solar patch or newly designed broadband device with contact Assy. (no cables). This file will illustrate how this is done.

You effectively remove the central processing unit CPU, the personal computer is not required and a laptop becomes redundant.

Conversely the following pages will outline how to remove the USB ports, remove the Top Cover Flash Units, Remove the battery and No charger and even the memory cards.

It effectively illuminates the cable from the computer and camera mobile and simplifies it to an easy mobile camera computer which can be easily packaged up and sold to the consumer in every market in the world.

It uses five core principles which will be diagrammatically outlined below:

- 1) The use of Multiple flash units, built into the body of the camera.
- 2) The Use of Computer Contact Assemblies which removes the need for USB ports.
- 3) A Mobile Phone with Built-in mouse technique docked into the keys, which customizes and mechanizes the desktop computer to a beautiful system transferable all over the world.
- 4) On the standalone it's the principle of "what you see what you get twice".  
WYSIWYG
- 5) Autonomous Keyboard Vibration to recharge the camera mobile phone.

## ADVANTAGES:

So effectively you can have:

1. Autonomous Road/ Bridge/ Train Tracks built with minimal humans no sweated labour.
2. Autonomous house infrastructure building.
3. Plant meters with plants pots which indicate if water or light is required.
4. No more requirements of PC' s and Laptops.
5. This system could lead to large government contracts around the world, where there is constant Wi-Fi outdoors and no need for Car Registration Plates, No Cards for driving License (E-License),Traffic Light switch Cameras and speedometers built in to them with quad lights ,No Passports (E-Passports), diversion off lights away from civilian buildings, new type of camera multimedia messaging service and file transfer ability globally. No need for telecom towers and just one live operating system which throws out Wi-Fi constantly with out disruptions. Also Automatic Ignition Start-up s and no need for key s as Door locks can open with pass codes.  
Printers or Calculator s built on and in to the Keyboard via having computer contact Assemblies around them.
6. There could effectively be a transfer of data from the larger TFT to the Keyboard without a cable, just by using computer contact assemblies.
7. No Mouse
8. No Cables.
9. No USB Port which is replaced by contact assemblies.
10. No PC
11. No Lap Top.
12. The Mobile Camera Phone becomes the sole system OPERATING SYSTEM WHICH IS THEN DUPLCIATED TO THE UPPER TFT SCREEN.
13. No Top Cover with now built in flash units in the body
14. No Charger No Battery because there is front solar panel and motion detection.
15. No Body Mount , No Rear Mount, No diaphragm
16. NO CMOS CCD
17. No shutter system?
18. No Telephoto of Wide angle Lenses
19. NO Memory cards or no sim cards
20. SOLAR REAR COVER WITH MULTIPLE FLASH SPOT UNITS
21. A different type of Main PCB or Infinity Processor.
22. The Hand Set Act s as the Operating System thereafter "save all information direct to hand set".

## Further ADVANTAGES:

### ADVANTAGES

There is No Desk Top PC effectively, you use the operating system from the mobile and duplicate the LCD image from there on the TFT monitor Screen.

Therefore low shipping costs, light weight.

Portable PCs you can take and use anywhere in the world with the mobile.

This will make file saving and sharing easier, allow you to save all PC file data on to the mobile.

You can manipulate and download various apps and use is symmetrically like a PC.

There are not many cables involved in developing this PC, only one which can also be used to charge the Mobile.

There may be no requirement of Main PCB with a No USB port as the data is being "reflected or mirrored" on to the larger TFT Monitor screen.

Perfect for various industries such as Education, Stadiums, Banking, Stock Exchange, Healthcare and Offices and domestic purpose. The education system can build the PC into the table and give each child a mobile which can then be used at home and at school etc.

In economics this will shift the Production Possibility Frontier (PPF) outwards of an economy due to use of technology.

This may alleviate Poverty in India and Africa and Brazil as many people can't

afford Wifi/Broadband due to poor connectivity. Therefore the use of Optimum Wifi on the mobile can make communication far greater. They can not afford conventional PC's either with Desktops which are complex to fit for them and difficult to use.

This can be built in different sizes and shapes with various colours, black, blue, red, green etc.

There will be no need for peripherals such as USB Stick or Memory Cards as all the data should be saved on the phone.

A network of PC's can be built in various shapes.

New innovation. The advantages appear to outweigh the disadvantages.

This design effectively customizes the desktop making it sleeker and more appealing to younger markets as its easier to assemble and use.

There is also effectively one gadget, one phone, one mobile, one DSLR, one compact camera operating as one Mono Device.

This computer has not been seen on EPOS systems or tills anywhere. In order to turn it in to a till just add a till machine at the bottom of the computer, then retailers could use it, such as hairdressers and keep the tax records more efficiently.

This could make Land Lines Mobile and Transferable.

No tills. People can operate this small PC on a trolley on a intranet and scan the goods and debit from their phone and take the trolley straight to their car bypassing tills. Hence saving labour costs and adding to profit.

Pay direct on flight, bus, train. You do not need to pre-book via a travel agent, just check the time table and pay directly on flight, train or bus. Just dock your phone on the airline intranet and print out your ticket. No need for oyster cards.

This will drive human capital levels in IT and hence come before bio chipping people.

Cashless society. Less Cash Theft Crime.

Mopeds and motor bikes can have built in PCs so they can instantly track an order from their bike.

If its manufactured from Latest Solar panel material and motion detection technology there may be no mains or cables of plugs or 220v outlet.

Individuals can self document themselves and improve IT human capital levels, document and file. Very easy to do with scanning techniques.

This might be alternative to E-Passports and quicker and effective visa systems.

Reduce Stress, as people do not have to commute to work, therefore reducing traffic congestion and pollution.

Transform teleworking, people can work from home and turn in to a small service organization.

Can be fitted in Rear Seat of Cars, Rickshaws, Cycles, Tables, Chairs, Buses, Coaches, Flights and other Transportation hubs, i.e. Trains.

Could reduce crimes, by quicker information to the police and quicker preventions.

Improve information in Court Cases and Reduce Waiting Times in NHS and in General Service Providing groups.

Through economies of Scale this could reduce the price of the computer, hence make it affordable for all.

Make The operating System "live" like the internet?

Make the operating system work on batteries or without cables and power supply.

Wifi Towers Could be built

No more keys, as the passcode can be used to open door locks in homes and offices.

Automatic Shutters Opening and closing for retail shops on high streets on time daily.

No more 'on and 'off switch on the camera mobile.

This computer uses contact assemblies found on DSLR Cameras inside the mirror box which communicate with the lens to the body LCD.

Make the Land Line Mobile Globally.

No need for Mouse with a cable as this is built in to the mobile camera.

This is a computer which requires no cables no usb, no pc, and no laptop.

Can be easy to assemble from the customer point of view

Can be packaged and sold in the open market.

A duplication of mobiles can generate security.

Pay by Key

Artificial Ignition Start up and Stop  (Ctrl) ▾

**FIGURE 14: THE GAME CHANGER TO REMOVE THE USB CABLE AND SOCKETS WITH THIS HISTORIC COMMUNICATION METHOD OR SPAREPARTS.**

Below is what I am trying to discuss, it outlines communication of Data and Physical movement data i.e to un lock and lock doors via the connection of two contacts.

The first one is exemplified in Figure1.The External part of the lens contact assembly communications with the external part of the DSLR Side body show in Figure 2.

They both poses an internal make up, the lens side has the Main PCB hence forth the alteration of Main PCB in the mobile camera.

Perversely the DSLR internal circuit is made up of contacts circuit which connects into the DSLR Main PCB or Mirror box allowing effective movements of the mirror and AFdata communication transfers on to theLCD for Display via the internal Main PCB VIA PINS. Thus no requirement of any Cables or USB Sockets, *only if the Camera Mobile is sleeping on the Keyboard with the built in contact connections pins. Please note there will be a Flip Connection on the Camera.*

**FIGURE 14: LENS SIDE CONTACT ASSEMBLY EXTERAL AND INTERNAL COMMUNICATION:**



**INTERNAL**



**EXTERNAL**

**FIGURE 15: THIS IS THE BODY SIDE CONTACT ASSEMBLY ,INTERNAL AND EXTERNAL COMMUNICATION WITH THE LENS WHICH DOES NOT REQUIRE CABLES.**

## **EXTERNAL**



## **Internal35mm(8PIN)**



So if the current market USB Cable or socket is replaced with the above type of communication Referred to as“ Computer Contact Assemblies” CCA vast computers can be e built.

The keyboard is essential in this project as it has to be redesigned but is pretty cheap in the market place.

All data will be saved directly on the mobile camera via the systems mentioned earlier. Such as the Twin display (WHAT YOU SEE IS WHAT YOU GET TWICE ,WYSIWYGT) from Camera Mobile to the Larger TFTS Screen when camera mobile is sleeping on the key board with computer contact assembly built in the made In the internal DSLR Contact assembly built into the keyboard.(Flick the Contact Flex in to the Internal Keyboard)

The Service Costs will predominantly be a fault in the communication of the Computer Contact Assemblies it could be minimal compared to the masses of connectivity faults with the cable and USB Socket via misuse and tethering.

So effectively once built you will get a New Type of Computer where data is taken all over the world.

***FIGURE 16: E-GAME CHANGING CONTACT ASSEMBLY***

Below is a sample of the contact assembly which just needs to be reshaped straight and attached to the right and left side of the mobile or camera phone or top and bottom. This will effectively lead to turning the camera or mobile phone into a very smart computer.



Proto type of the Gold pin

Contact Assembly .

BOTTOM

TOP



35mm

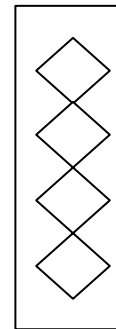
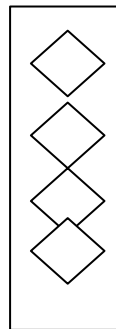

If one horizontal long row on contact assembly on the base of the camera phone does not work, then may be a row of two or more contact assemblies can be used to transfer data.

I.e. Transfer data from the camera mobile phone LCD Display to the Upper TFT Screen via Flexible Cables/Printed Circuit via the hinge and display what you see is what you get twice by using the mobile phone as the operating system.

This has no Personal Computer no CPU and No Lap Top and Separate Land Line Phone, it s all built in. This is effectively a new concept type of powerful computer using one or more database gadgets like a camera mobile phone. This can be forecasted to control Global Money Supply via New ATM Computer Systems.

Even Banks don't use this type of machine, it very novel and interesting to say the least.

TOP of Camera Mobile Phone



Bottom of Camera Mobile Phone.



X 4 Good Computer Contact Assembly Connectivity.

**FIGURE17: TWIN FLASH & QUAD FLASH & MULTIPLE**  
**FLASH UNITS**

TWIN FLASH

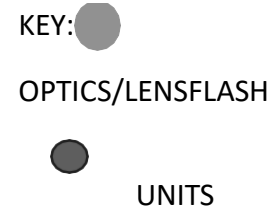
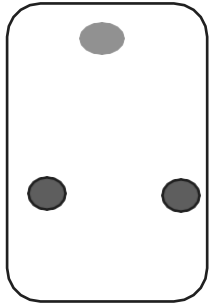

**TWO FLASH UNITS BUILT INTO THE CAMERA BODY ABOVE ON A CAMERA TO ENHANCE  
NIGHT / DENTAL PHOTOGRAPHY AND WHICH CAN ALSO BE USED AS ADDITIONAL LIGHTING SUCH AS A TORCH**  
QUAD FLASH UNIT

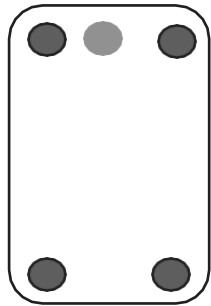

**QUAD FLASH UNIT WHERE THERE ARE FOUR FLASH UNITS BUILT INTO THE BODY OF THE FRONT COVER OF THE COMPACT CAMERA OR DSLR OR MIRRORLESS CAMERA, HELPS TO INCREASE QUALITY OF LIGHT.**

IN DSLR OR MIRROR LESS CAMERAS THERE IS EFFECTIVELY NO TOP COVER AND NO VIEW FINDER UNITS NO HOT SHOE NO SUPER IMPOSE PLATE AND NO PENTAPRISM AND NO FOCUSING SCREEN.

HAVING MORE THEN ONE FLASH UNIT BUILT IN TO THE BODY OF THE CAMERA ALSO REDUCES THE NEED FOR A SPEED LITE FLASH GUN. THERE FORE, CUTTING THE *SERVICE AND REPAIR COST* OF CONTINUAL DEFECTS IN THE HOT SHOE WHERE BY TH E HOT SHOE ASSEMBLY SNAPPS AND HOT SHOE BECOMES LOOSE. NO HOT SHOE UNIT.NO TOP LCD WINDOW,NO BUTTONS ON TOP COVER UNIT.

ALSO CUTS THE TIME IN CLEANING OR REPLACING SCUFFED FOCUSING SCREENS.

ALSO HAVING A TOP COVER PRODUCES DEFECTS SUCH AS THE ERROR05 O OR FLASH POP UP FAILURE. THUS THIS BUILT IN SYSTEM CUTS THE DEFECT RATE AND *SERVICE & REPAIR COST* IN REPARING/ REPLACING THE TOP COVER UNIT.

IT ALSO MAKES THE CAMERA APPEAR TO LOOK SLEEKER (FLAT CAMERA) AND FUN LOVING TO USE. NO HAND GRIP. ALL THE SYSTEMS TURN THE CAMERA IN TO A REAL COMPUTER HANDSET.

**Figure 18: REAL TIME SERVICE & SUPPORT –ALPHABETICAL & STRUCTURAL INVESTMENT IN OFFICE SHAPES.**

**HOW TO ACHIVE OPTIMUM EFFICIENT REPAIR FACILITY BY CHANGING THE STRUCTURAL SHAPE OF THE ORIGINAL OFFICE DESIGN WITH SOFTWARE**

The conditions:

- 1) You need good work flow i.e at least 75units per week for repair. May be multiple multinational contracts would be nice.
- 2) You have to have minimum SME with 1-5 or 1-10employees
- 3) You need to accommodate for the ultra- computer designs outline previously as well as havea RMS inposition. Such as Repair Management Software(RMS) like AYS Software canada,web based.
- 4) Colored Lin Bins with Organic Locations indifferent sizes to accomadate different sized products..
- 5) A department of Booking Repairs who can see empty bin locations and Department for Quality Control may be required.
- 6) A Row of Tools next to the shape would be ideal.

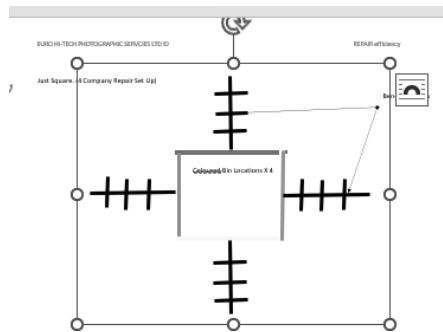
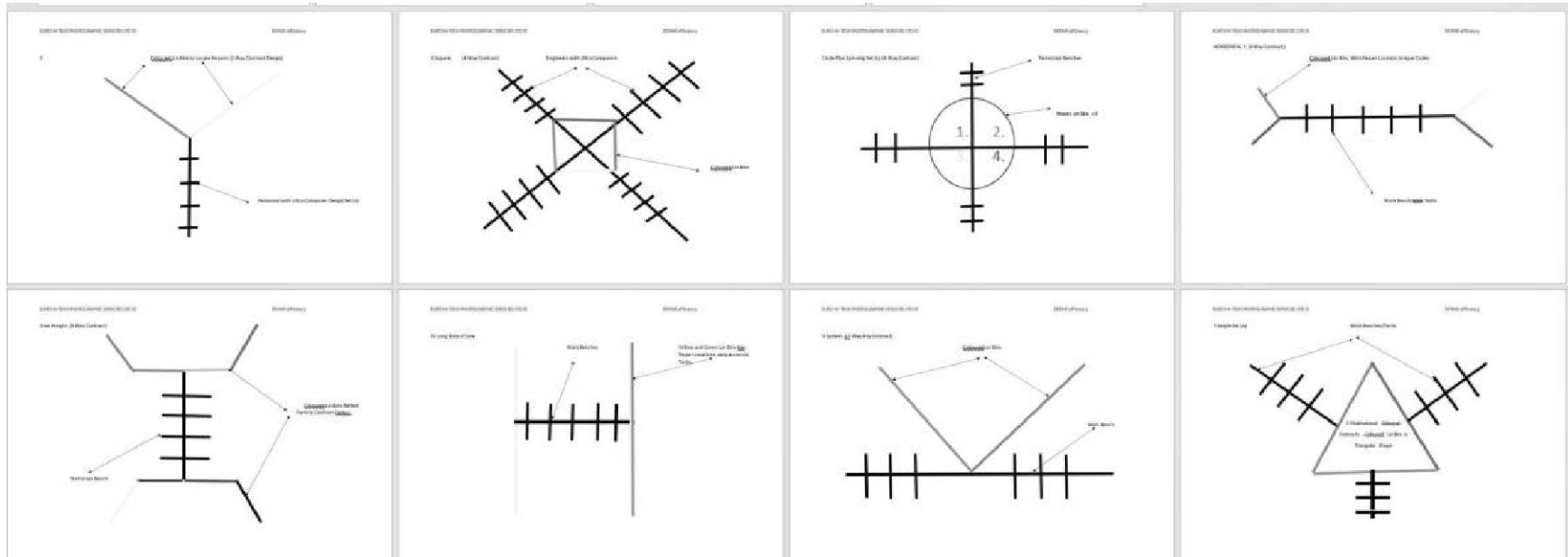

DISADVANTAGES:

- 1) Companies Can pull out of Contracts Any Time.
- 2) Techs Leave Bins which are awaiting spares lying around near by their area , wasting space.
- 3) Bin Sizes Could be too small once spare parts are put into bins as well as the products.
- 4) Cost of Land/ Area Might not make it practical
- 5) Spare Parts could fall on the floor and loose online Tracking
- 6) A Bin Located may be required.
- 7) Not enough space or not enough bins might be come an issue for more work.

**FIGURE19.IMAGE OF THE DIAL ASSEMBLY**



This can be used to scroll up and down the images when the mobile is connected or disconnected on or off the keyboard. This can be located on the front cover at the bottom or on the reverse of the handset.

**FIGURE 20. IMAGE OF THE MULTICONTROLLER JOYSTICK / MARBLE**

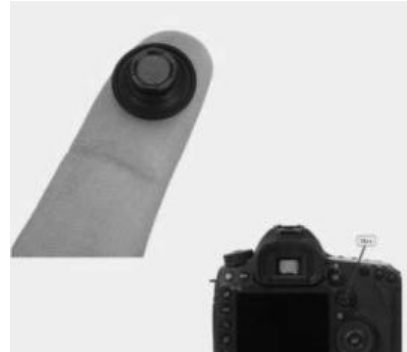

These Multicontroller joysticks are found commonly on EOS 5DMARK III they are used to scroll all around the LCD and make selections from menu options and selection made when depressed. They are on the Rear Cover of the DSLR Camera. This would be located on the front bottom of the vertical handset.

Also, a Marble (Roundball/rollable mouse) Could be used in replacement of this for more effective curser locations.

A double curser on the standalone would look nice, but one curser should do the service for multiple mobiles and havin gone masterphone on the right  
Or left of the key board on the base.

**Figure 21: NEW CONCEPT COMPUTER MOBILE WITH BUILT IN MOUSE SYSTEM-  
INFINITUDEIN 1Y**

Here we have the option of putting the mouse onto the mobile phone. It consists of left-and right-hand button at the base of the phone. With a Dial Assembly to scroll up and down with on the page and a multi controller joy stick or a rollable mouse to search the page with a cursor.

This is then docked or slept on to the keyboard with the built in mouse buttons with simply the contact assembly on the base of the phone as well designed on the mid keyboard.

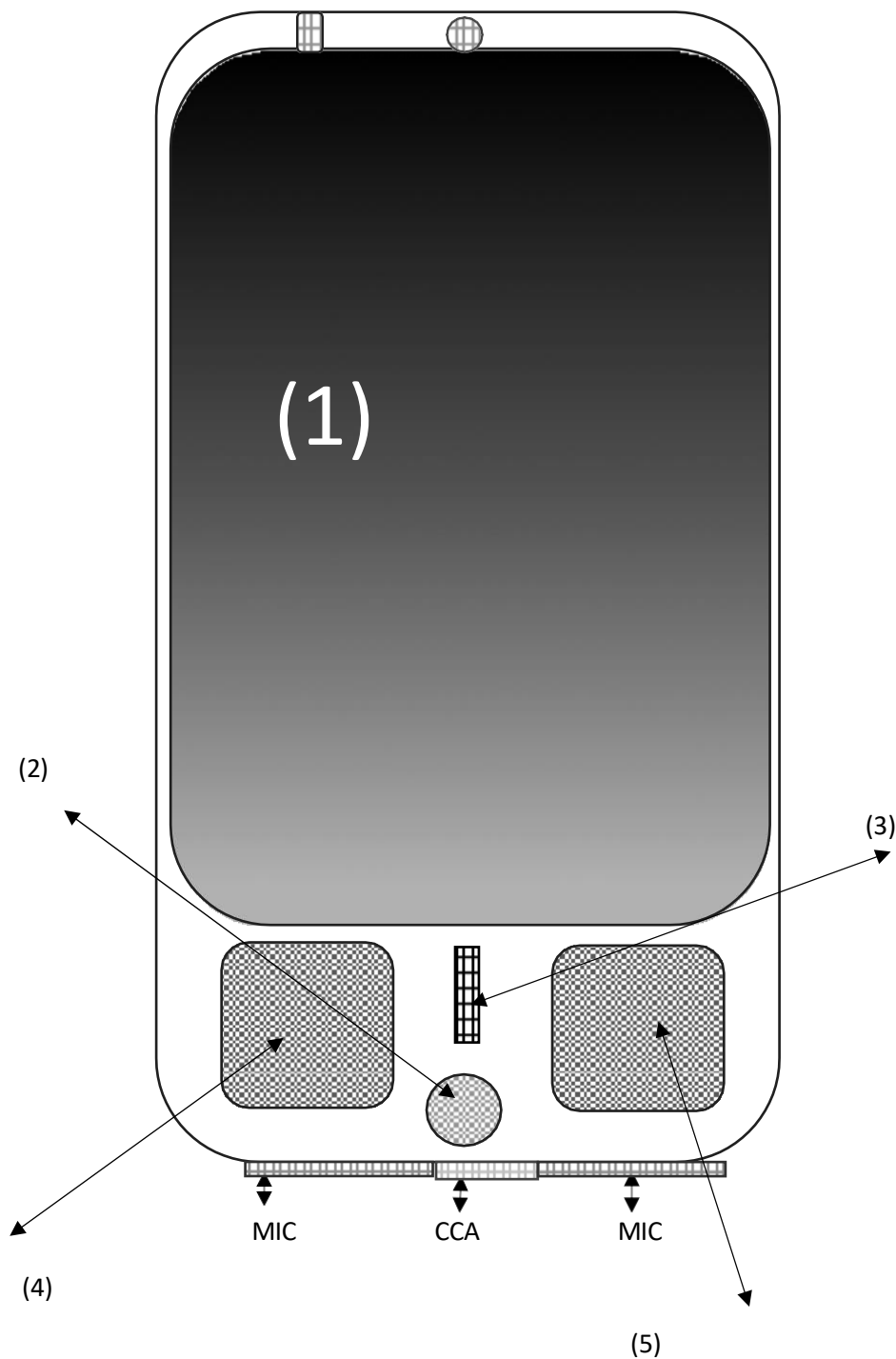

**FIGURE 21: KEY**

- (1) **FRONT LCD**
  - (2) **ROLLABLE MOUSE**
  - (3) **DIAL ASSEMBLY**
  - (4) **LEFT MOUSE BUTTON**
  - (5) **RIGHT MOUSE BUTTON**
- MIC = MIKE**  
**CCA= COMPUTER CONTACT ASSEMBLIES**

# UbiquityU2Y



Future3y



## **FIGURE 22: SIMPLE KEY BOARD DESIGN FOR LIVE OPERATING SYSTEM**

You get a live operating system once all FOUR products are connected down on to the key board simultaneously.

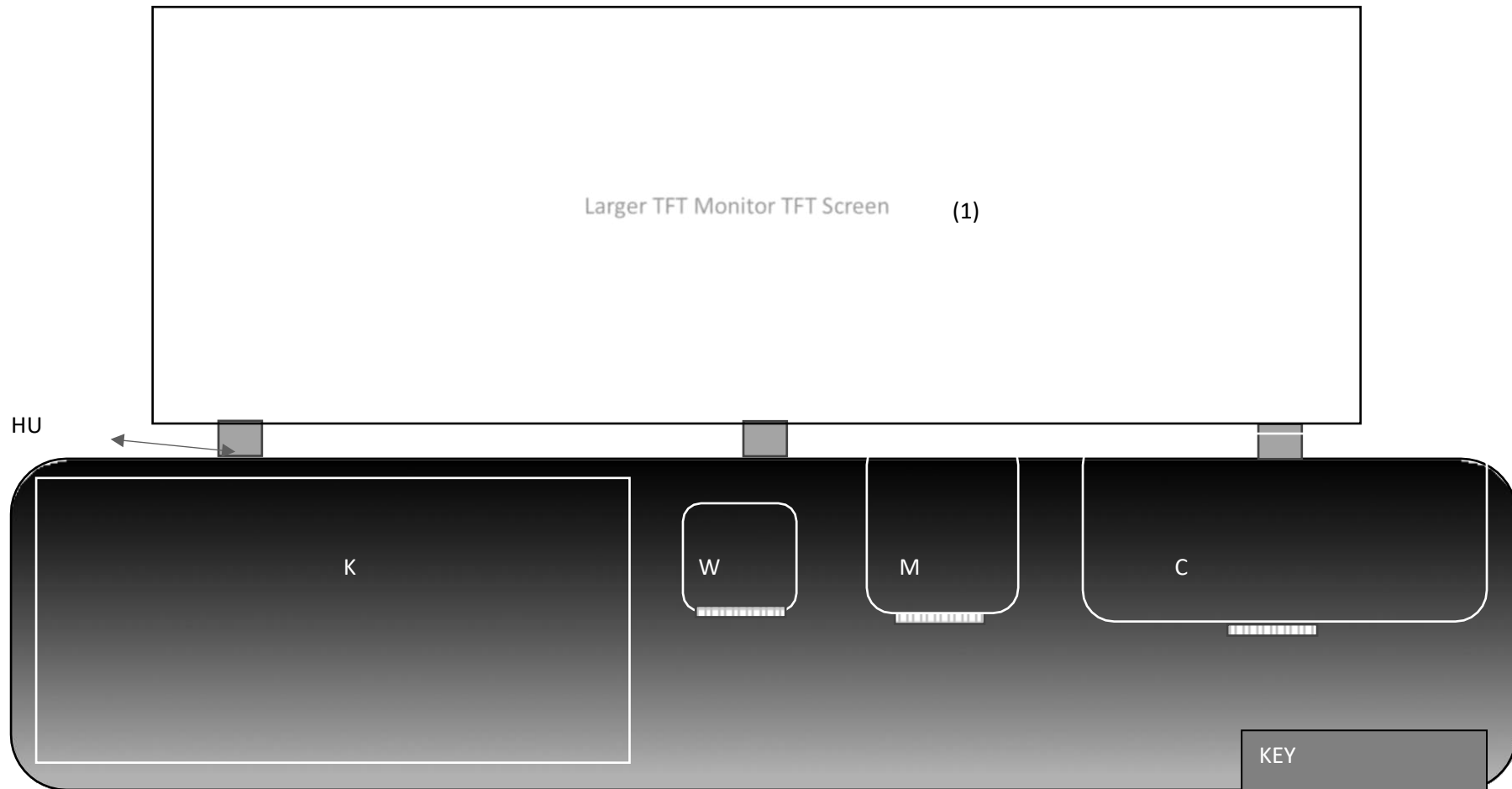

**FIGURE 22: LIVE OEPRATING SYSTEM**

**(1) LARGER TFT SCREEN-LCD PANEL**

**K = KEYBOARD**

**KEY= HOUSE KEY OR CAR KEY WITH CONTACT ASSY**

**W = WATCH**

**M = MOBILE OR HAND SET**

**C= COMPUTER PAD**

**HU= HINGE UNIT**

## BLISS BMCP M 1Y



## SEDUCTIVE SMCPM2Y



## EXCELLENT EMCPM3Y

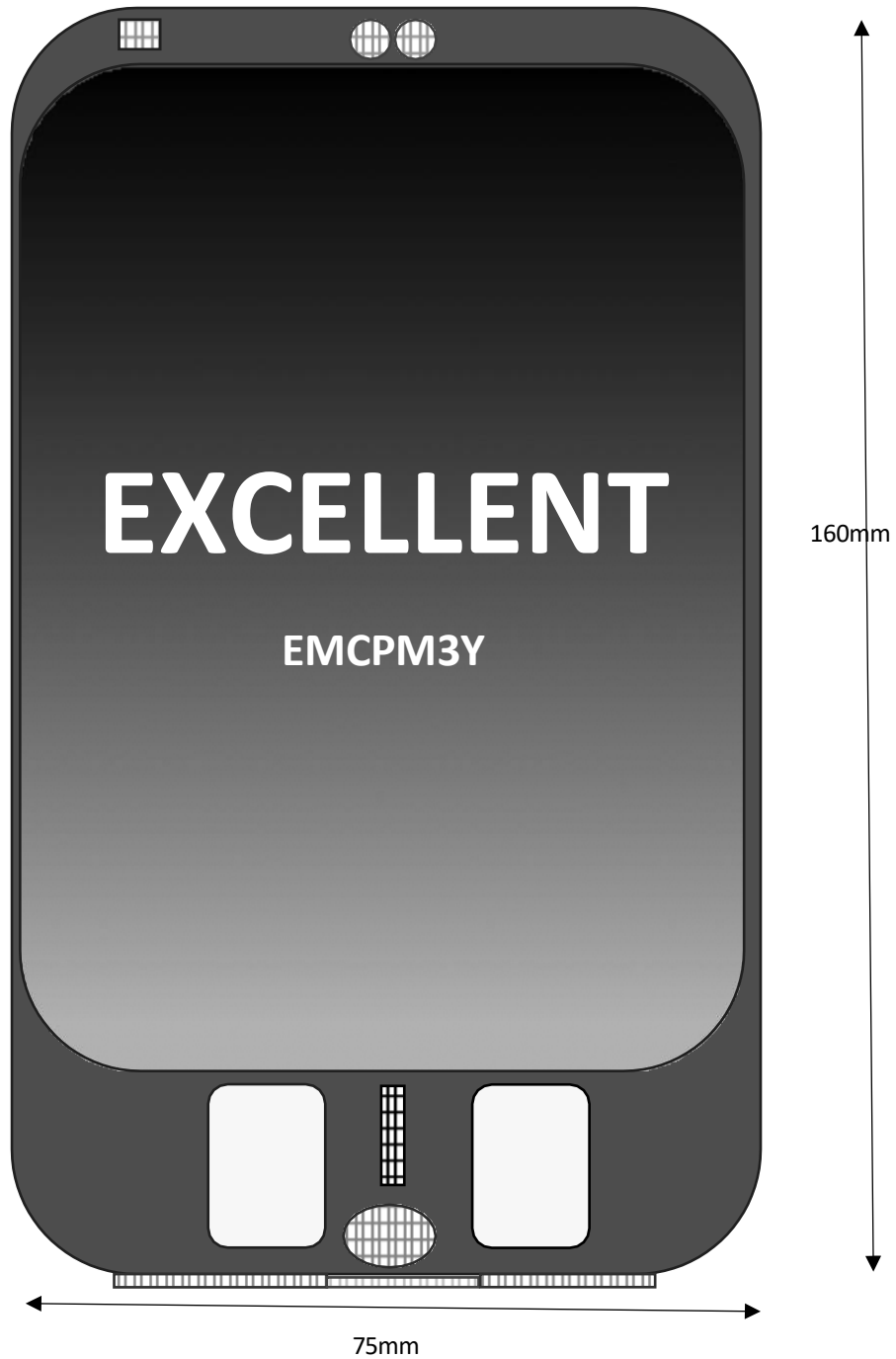
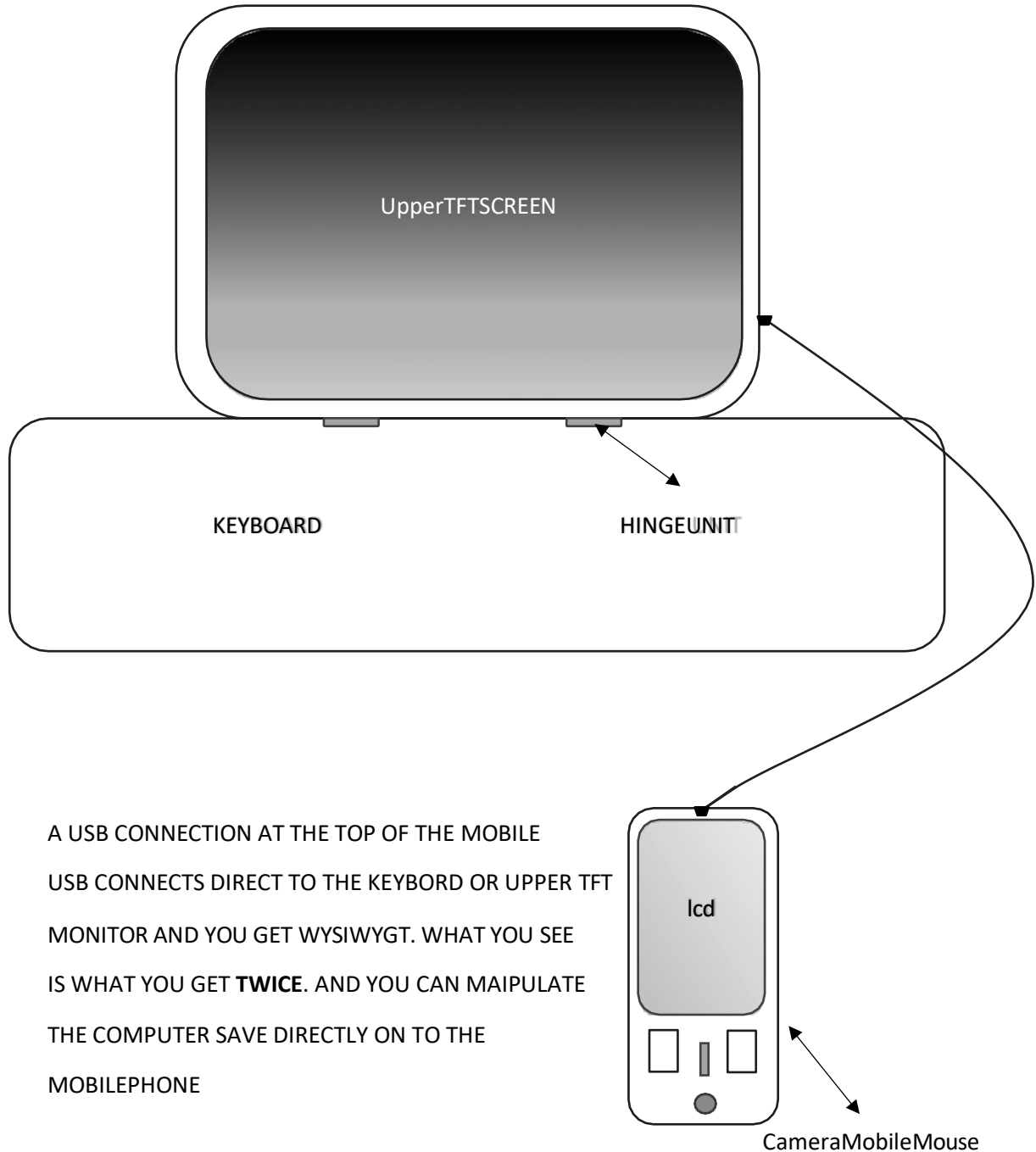

FIGURE 23: ALTERNATIVE OPTION OF CAMERA MOBILE COMPUTER WITH USB ON TOP

Here there is NO CPU and no Lap top .This could be one form of design.



But then again this is with the cable and USB, the whole of my exercise is to remove the USB CABLE via Computer Contact Assy and remove the cables from the computer to make it more efficient and portable. It would be difficult to network this with stack systems and N Plus Network Drives.

**FIGURE 24: THE CONCEPT OF MOBILE PHONE CAMERACASSETTE MECHANISM DECK SLOTS**

1. On the rear of the DSLR Camera you can build a mobile phone cassette deck eject mechanism where you slot the mobile into the rear of the camera where there are no more LCD built in to the DSLR camera. The cassette eject mobile phone LCD on the rear of the DSLR acts as LCD and thus docks into the key board via contact Assy around the rim in to the keyboard.

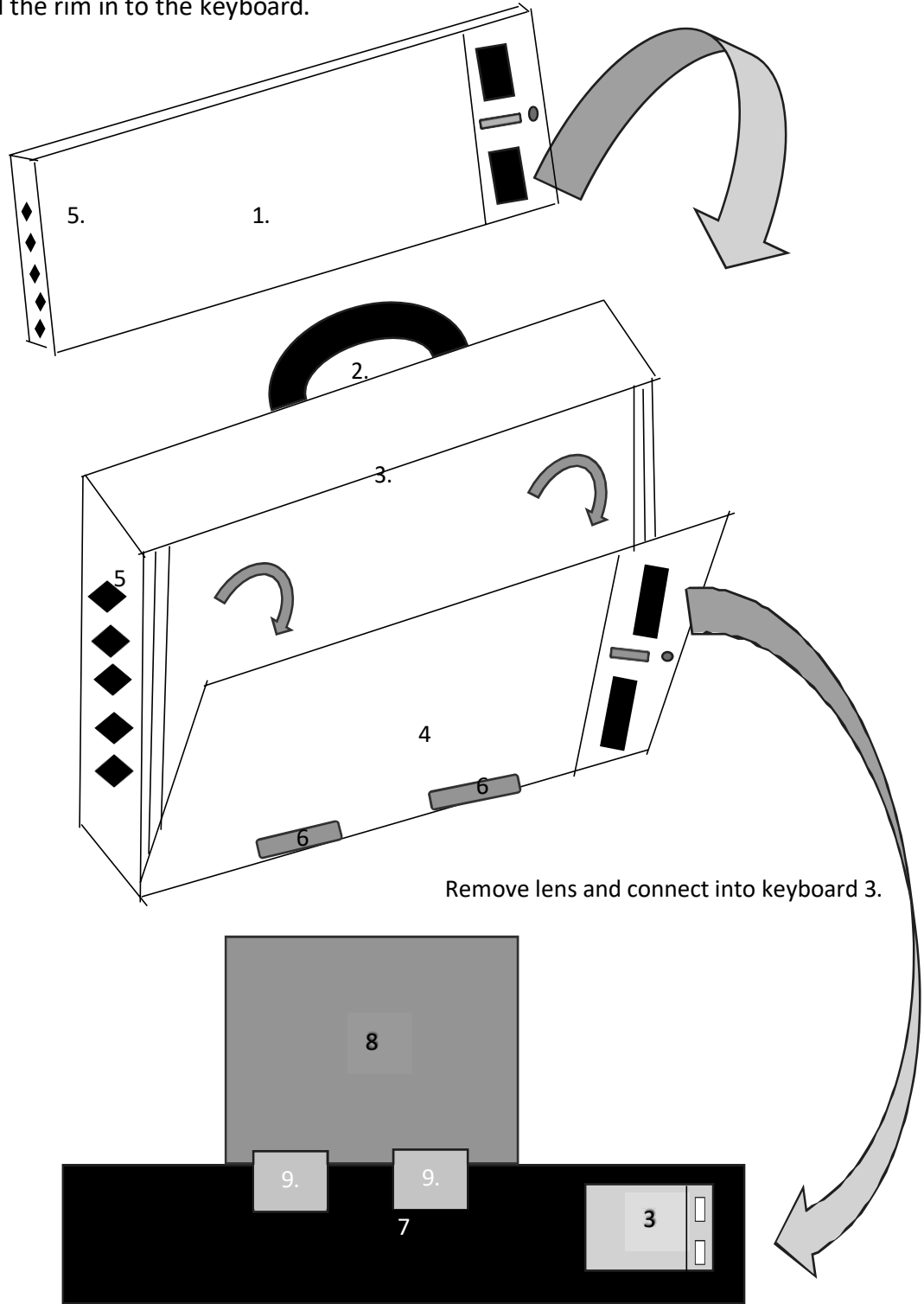
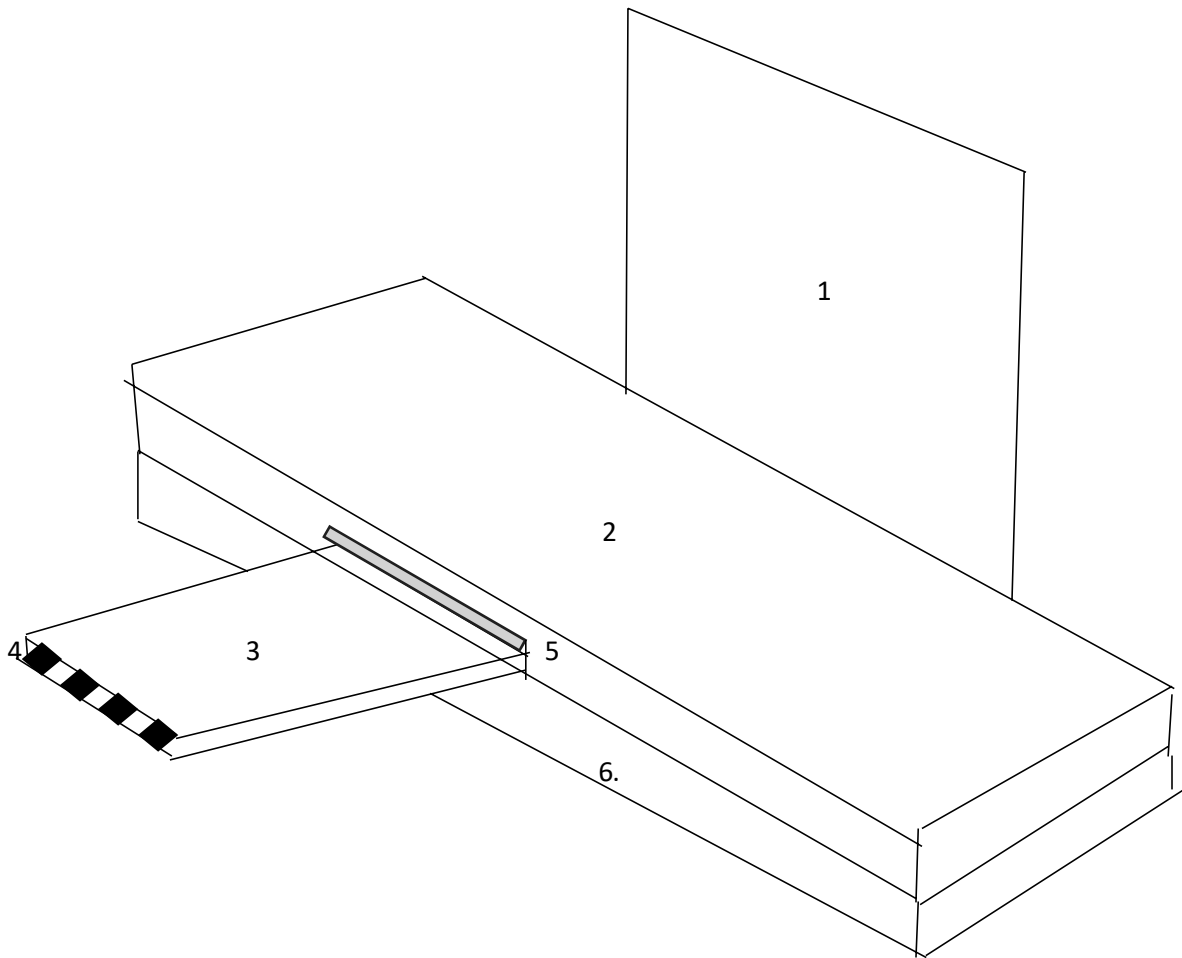

FIGURE 24: KEY.

1. CAMERA DSLR WITH LENS
2. FRONT LENS UNIT
3. MAJOR CAMERA BODY
4. REAR OF MAJOR CAMERA BODY THE EJECT SYSTEM
5. COMPUTER CONTACT ASSEMBLIES
6. HINGE UNIT
7. KEYBOARD
8. LARGER TFT SCREEN
9. HINGE UNIT CONNECTION FROM LARGER TFT TO KEY BAORD MAKING IT VERSATILE.

**FIGURE 25: THE VHS MOBILE MASTER CAMERA PHONE EJECT MECH SYSTEM COMPUTER.**

Here we have the master mobile camera phone built into the middle of the keyboard which connects and disconnect /LOADS like a vhs entering a video system, the key board is slightly more top to bottom longer. You can more then one master phone built in to the key board like a vhs vide mechanism system. You can add a built in Till under the keyboard and make it globally versatile. Or you can have **Stack MobileCamera Phone Keyboards** one on top of each other with eject and insert mechs for camera mobile camera,



## VHS CASSETTE MECH MOBILE PHONE DECK Key

1. LARGER COMPUTER TFT
2. KEYBOARD
3. CAMERA MOBILE PHONE
4. CONTACT ASSEMBLIES
5. EJECT AND IN SERT MECHANISM
6. Till Built into the keyboard.

**FIGURE 26: THE SINGLE X LCD MOBILE CAMERA PHONE CAMCORDER CASSETTE MECHANISM COMPUTER**

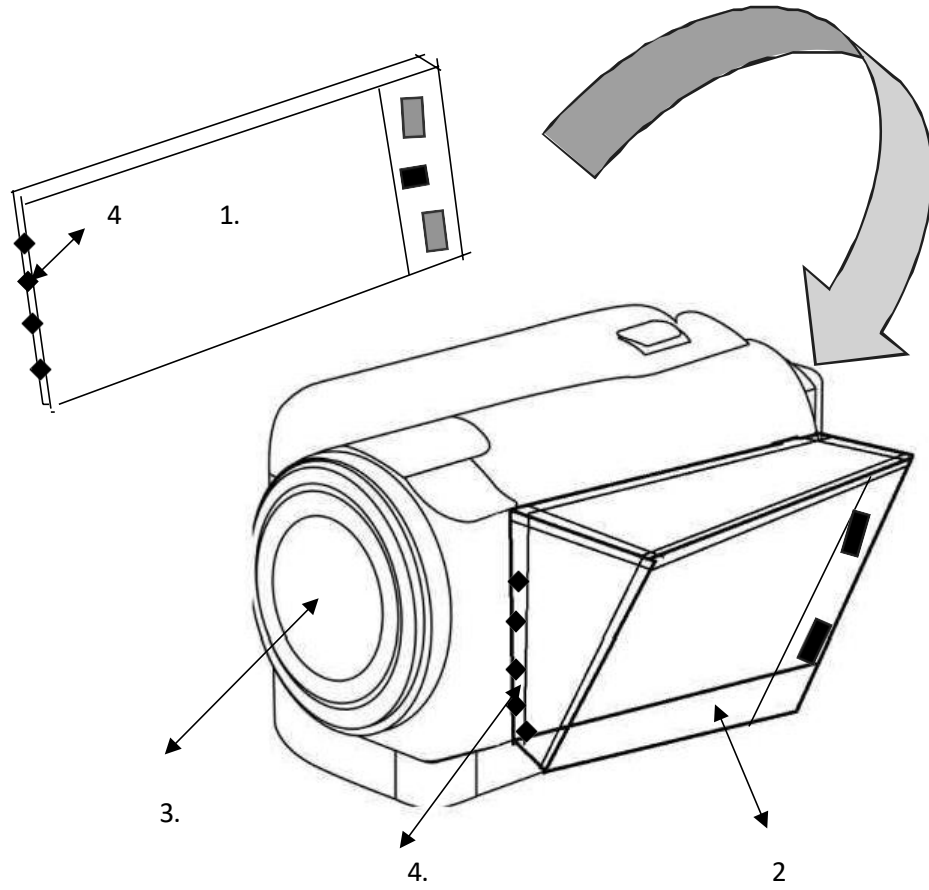

**KEY**

- 1. MOBILE CAMERA PHONE
- 2. CASSETTE DECK EJECT AND INSERT MECH FOR MOBILE CAMERA PHONE
- 3. CAMCORDER
- 4. COMPUTER CONTACT ASSEMBLY

**FIGURE 27: TEN FLASH UNIT PAD MOBILE CAMERA PHONE COMPUTER KEY A BORD  
CASSETTE DECK REAR OF COMPUTER PAD WITH TEN FLASH UNITS  
(REVERSE OFF)**

PRINCIPLE OF COMPUTER CAMERA MOBILE PAD(A)

Here we have a *computer pad with ten flash units* and one built in single lens unit on the top of the pad. With a built in mouse button on the bottom of the computer right/left button/dial assy /andr roller ball mouse respectively. The dimensions will be outlined Later but is similar to size of larger lft screen.

(A)

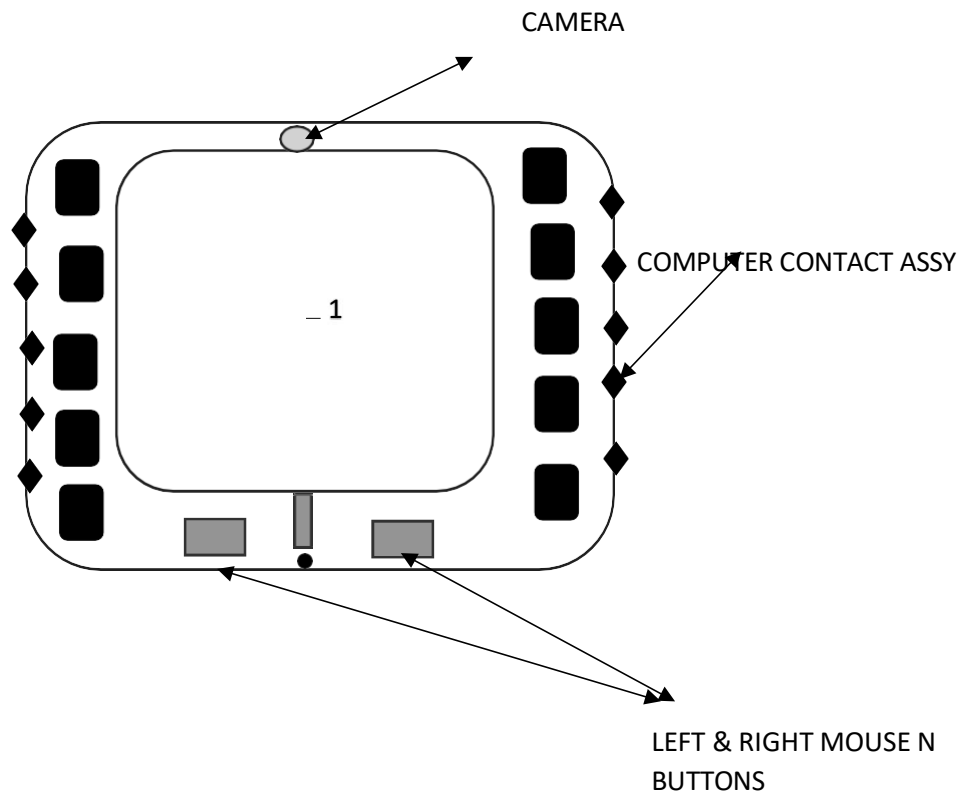

Principle B -Turning the *Computer Pad* into a new type Computer PAD SLR Big Camera Cassete Mech Deck.

Here The Initial Pad (A) is inserted to the cassette deck mech of the camera SLR Principle (B) Allowance of Functional Digital Infinity Camera.

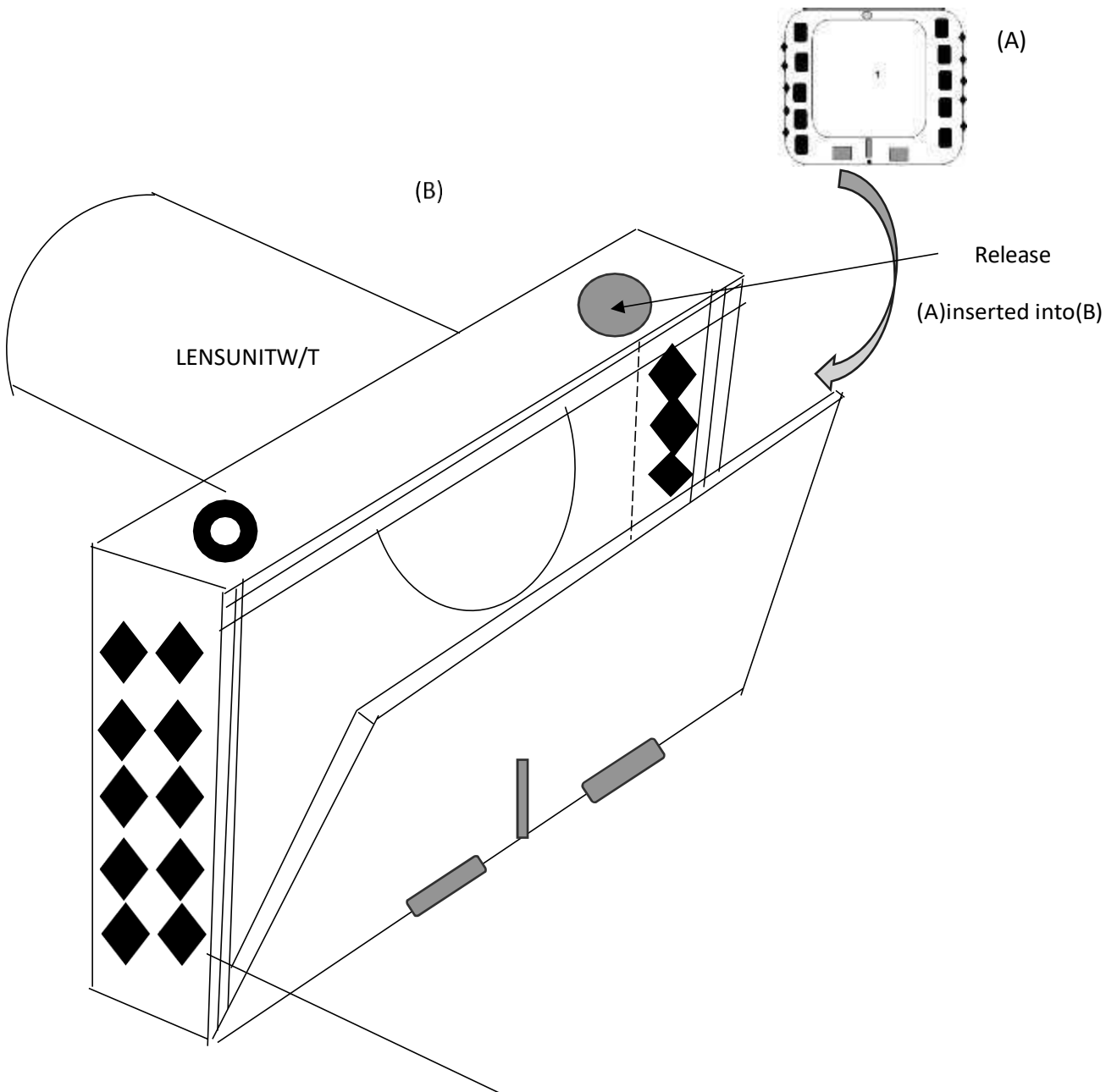

Dual Computer Contact Assembly for Effective Communication.

**figure 28: Principle(C)TheNewTypeMajorComputerCameraMobilePadCassettesDeck**

This principal B removes the lens detachable lens unit and then is docked into the key board to allow the use of a computer via the larger TFT as discussed previously. The Operating inthe Pad becomes what you see what you get twice with double cursor on the top of the largest TFTScreen. This is then computed and saved directly on the computer pad (A) and is in teractable.

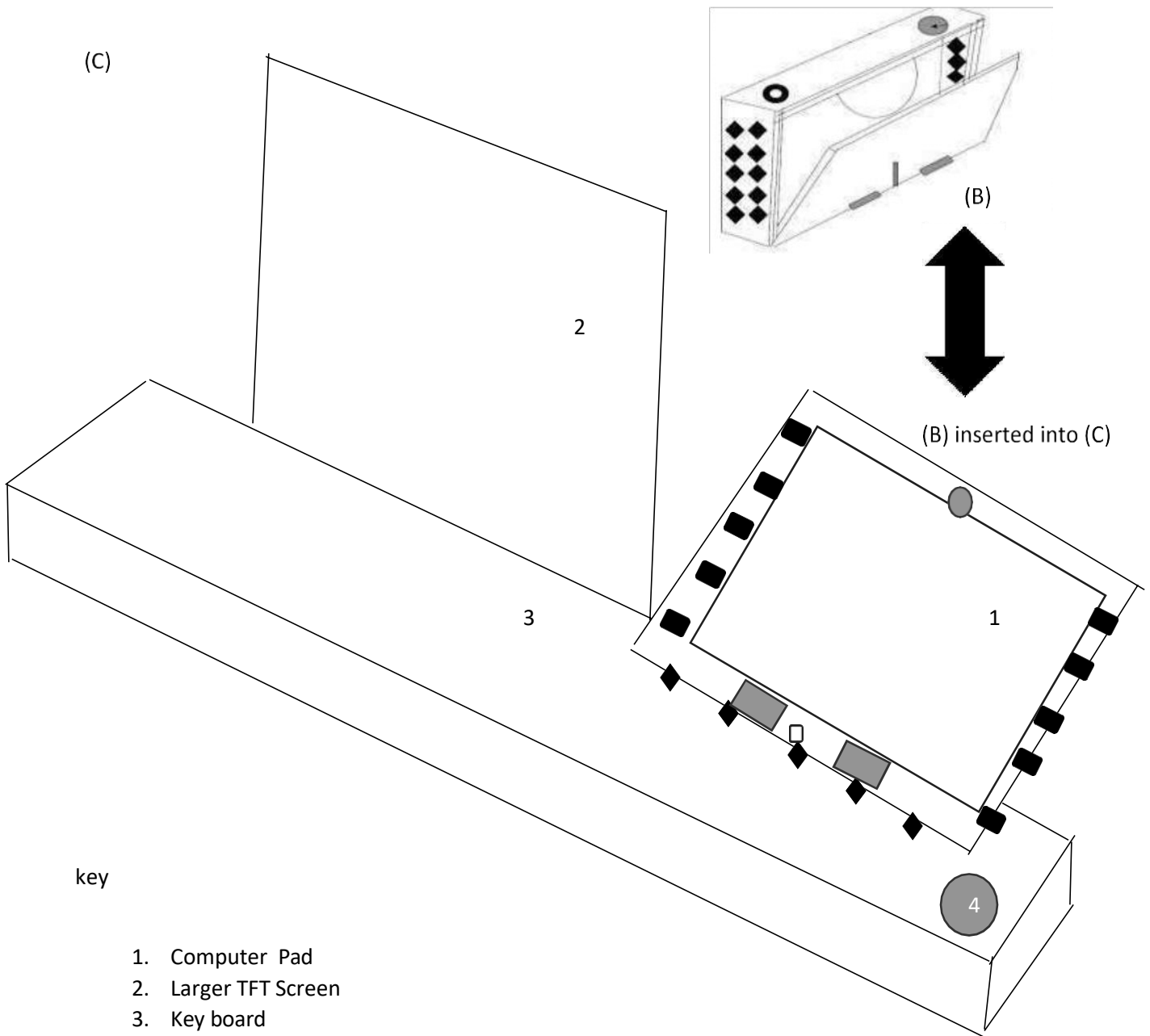

key

1. Computer Pad
2. Larger TFT Screen
3. Key board
4. Detached lens unit which could act as a release mech on the keyboard.

Ref: mech refer to mechanisms

FIGURE 29: HI-FI MOBILE CAMERA PAD COMPUTER CASSETTE DECK DRIVE SYSTEM

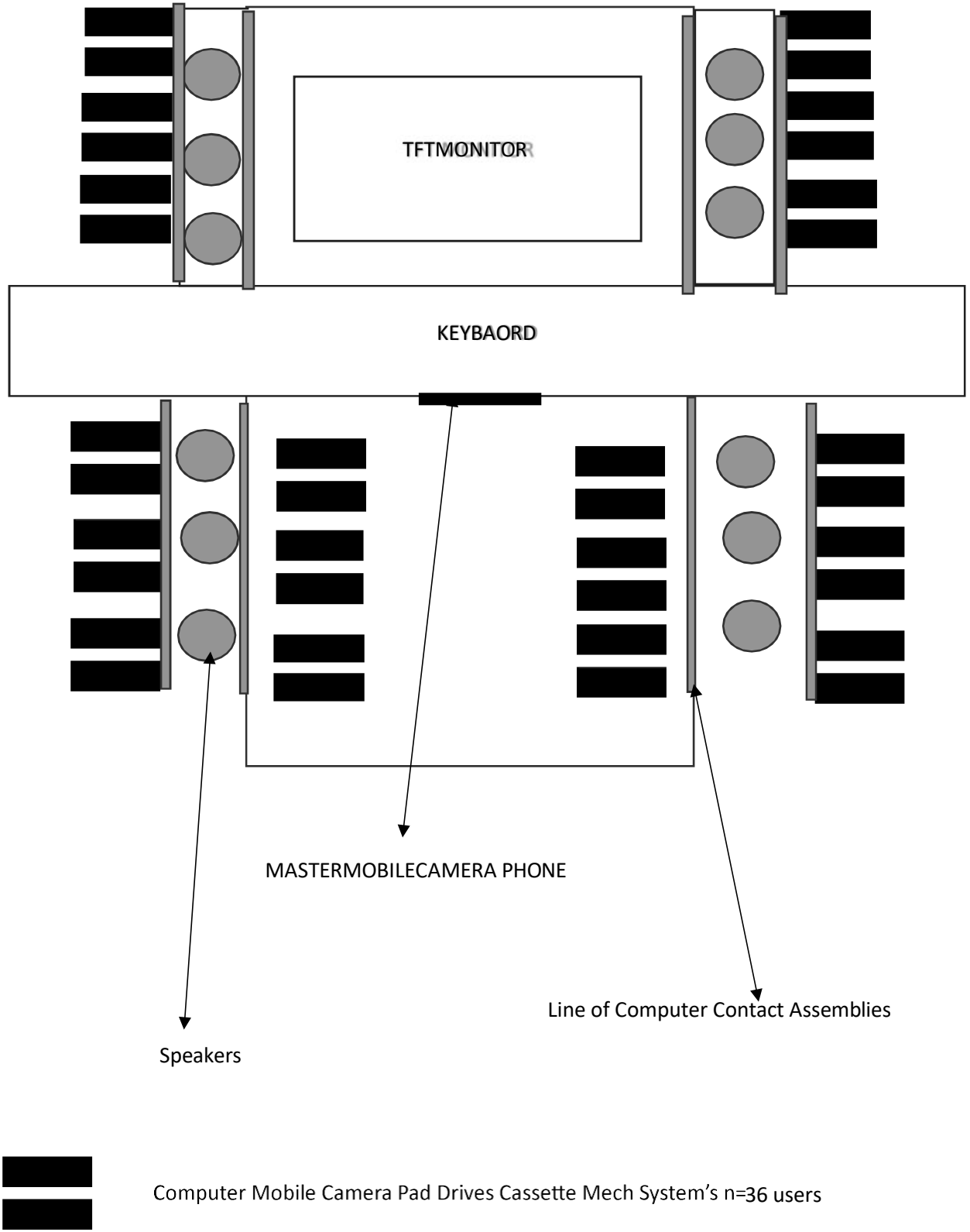
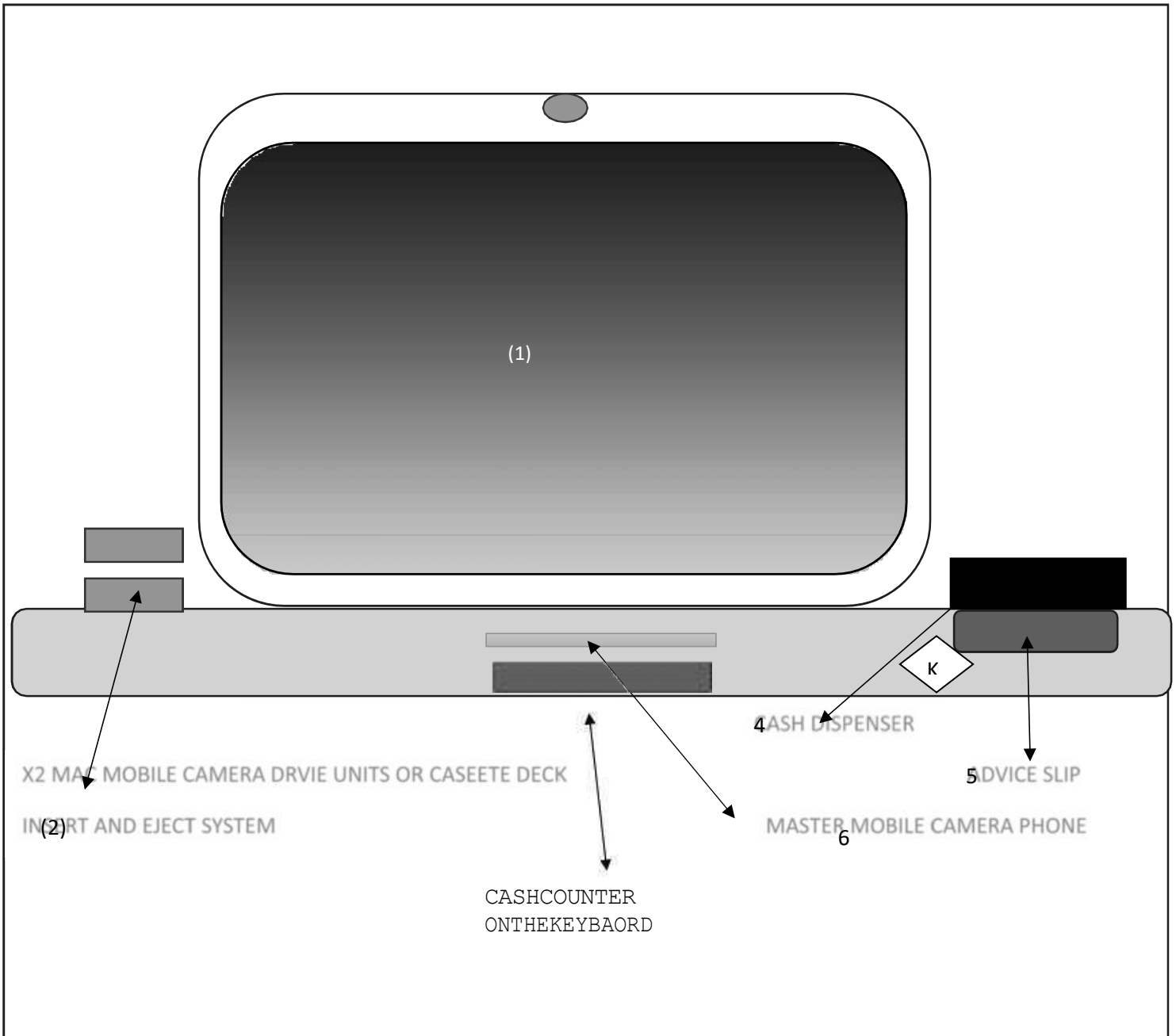

FIGURE 30: THE NEWLY SET INTRANET ATM



**FIGURE 31: ATM KEY:**

- (1) LARGER TFT SCREEN**
- (2) X2 MOBLE HANDSET DRIVE UNITS OR CESSETTE DECKS INSERT AND EJECT SYSTEM**
- (3) CASH COUNTER ON THE KEYBOARD**
- (4) CASH DISPENSOR**
- (5) ADVICE SLIP**
- (6) MASTER PHONE ON THE INSERT OF THE KEYBOARD COMMUNITCATING WITH THE USER**
- (K) HOUSEHOLD OR CAR KEY SWIPE OR SWAB**

**FIGURE 31: NEW TYPE OF COMPUTER MOBILE PHONES (3 WAY FOLDABLE COMPUTER PHONE)**

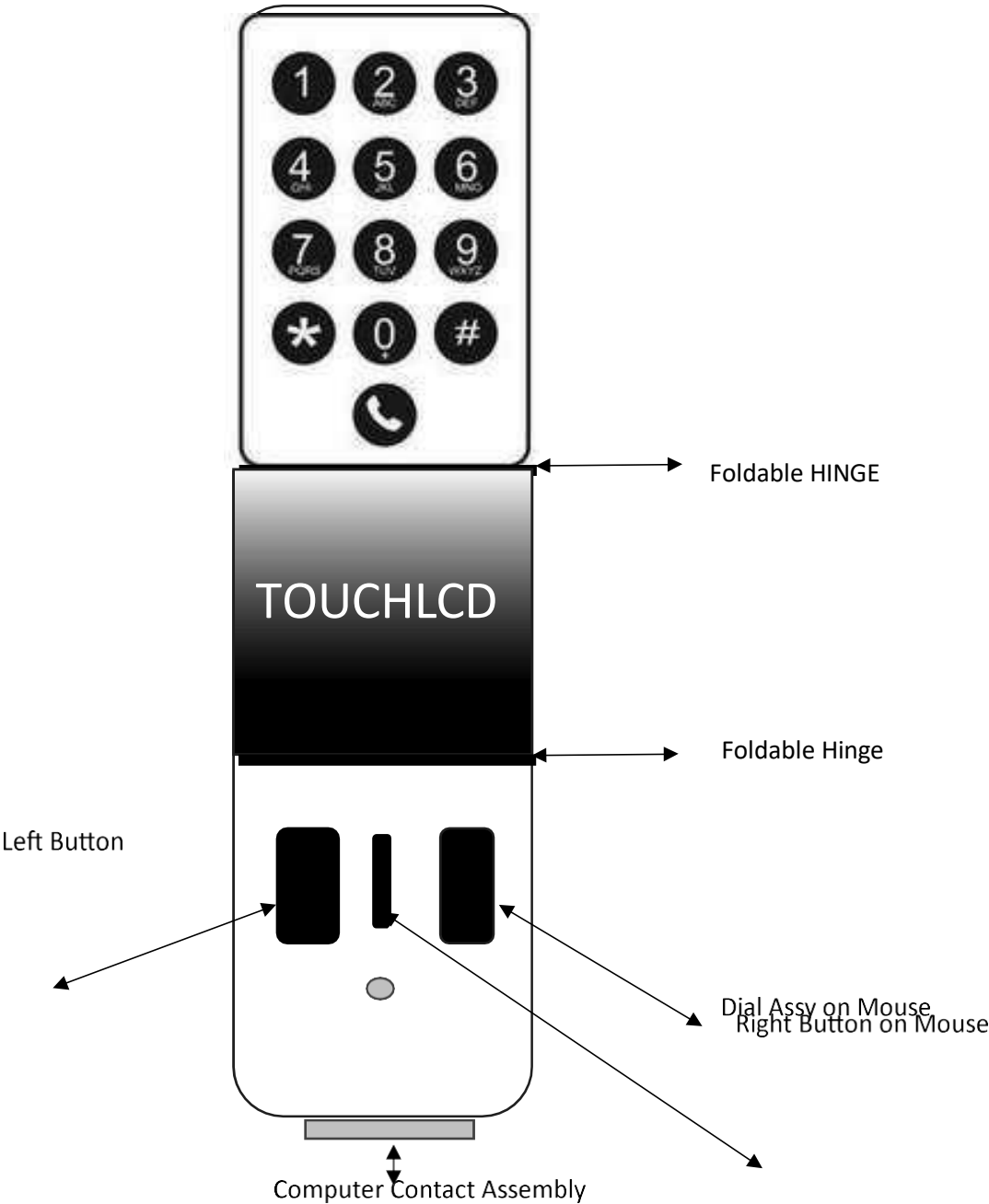

**FIGURE 32: Budget End Super Computer Phone**

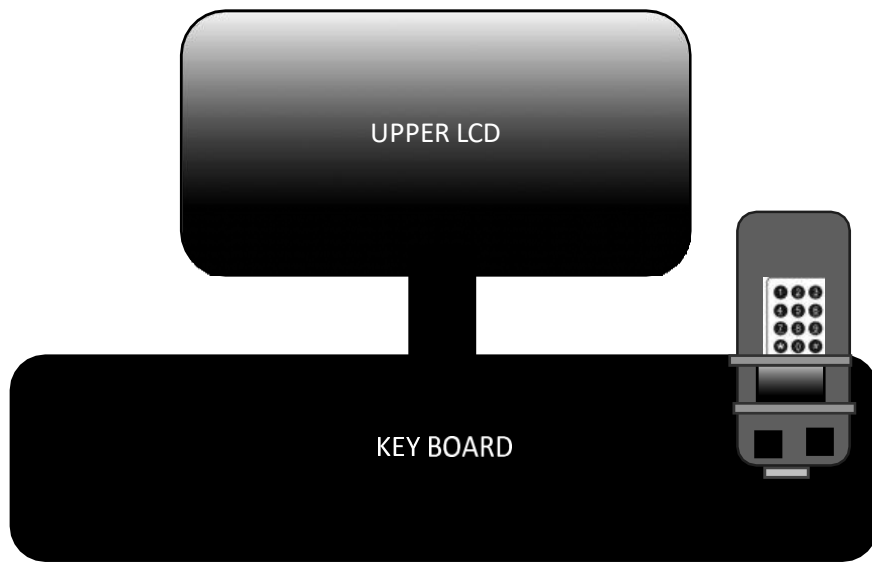

**FIGURE 33: STANDING UP COMPUTER (SUC) OR EVEN CASH LESSTILL**

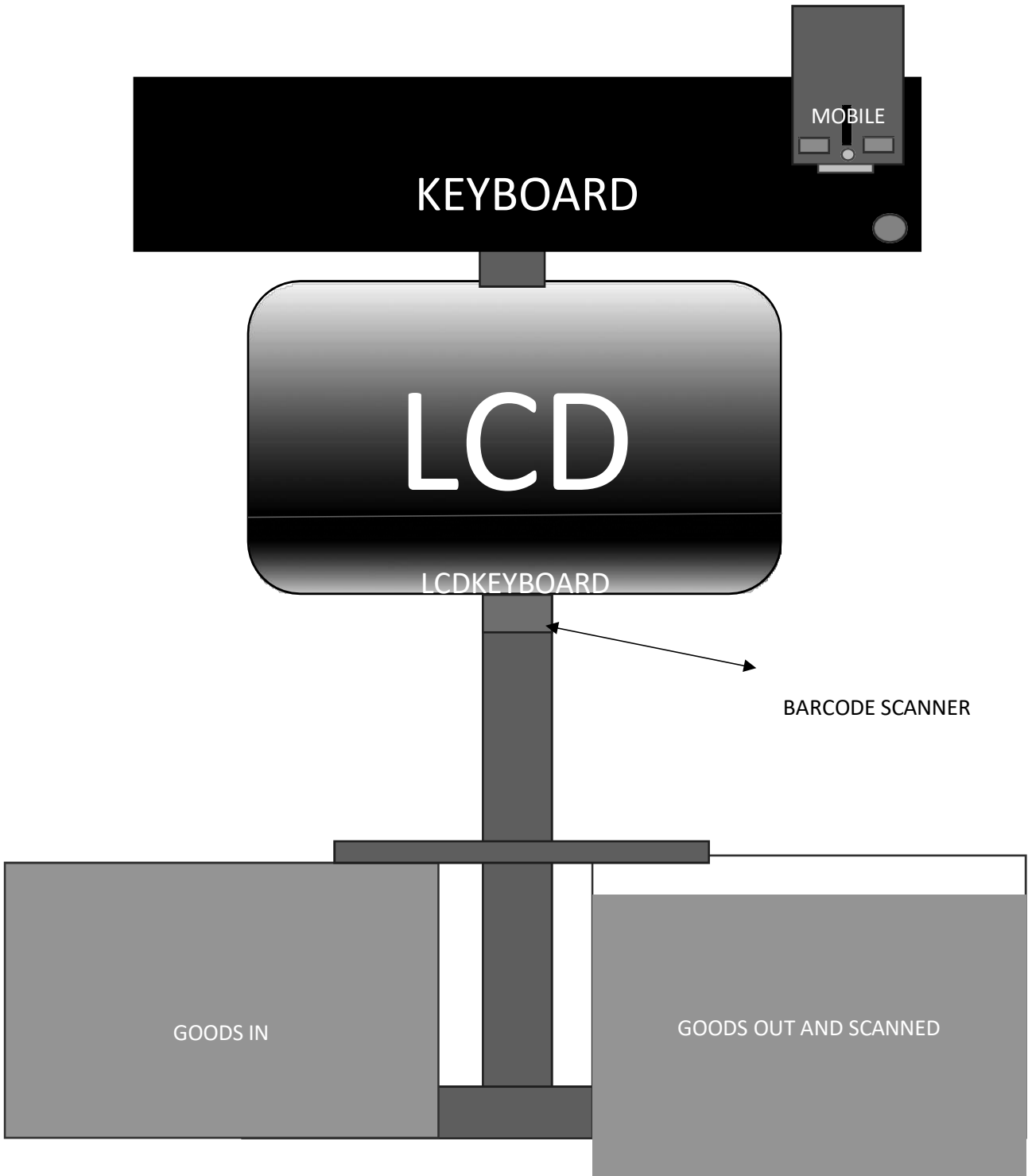



If one horizontal long row on contact assembly on the base of the camera phone does not work, then may be a row of two or more contact assemblies can be used to transfer data.

I.e. Transfer data from the camera mobile phone LCD Display to the Upper TFT Screen via Flexible Cables/ Printed Circuit via the hinge and display what you see is what you get twice by using the mobile phone as the operating system.

This has no Personal Computer no CPU and No Lap Top and Separate Land Line Phone, it's all built in. This is effectively a new concept type of powerful computer using one or more data base gadgets like a camera mobile phone. This can be forecasted to control Global Money Supply via New ATM Computer Systems.

Even Banks don' tuse this type of machine OR KEY SYSTEM ,it very novel and interesting

to say the least. TOP of Camera Mobile Phone

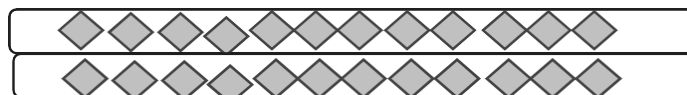

Bottom of Camera Mobile Phone.



X4 Good Computer Contact Assembly Connectivity .

### **FIGURE 34: Principle1**

Conversely when embedding the camera mobile phone into the keyboard a cassettedrive player mechanism can be such like built in to the keyboard. The Sony automatic eject mechanism is to noisy and colossal, keep it simple by having a simple cassette player holder like system. With one eject button on the keyboard.

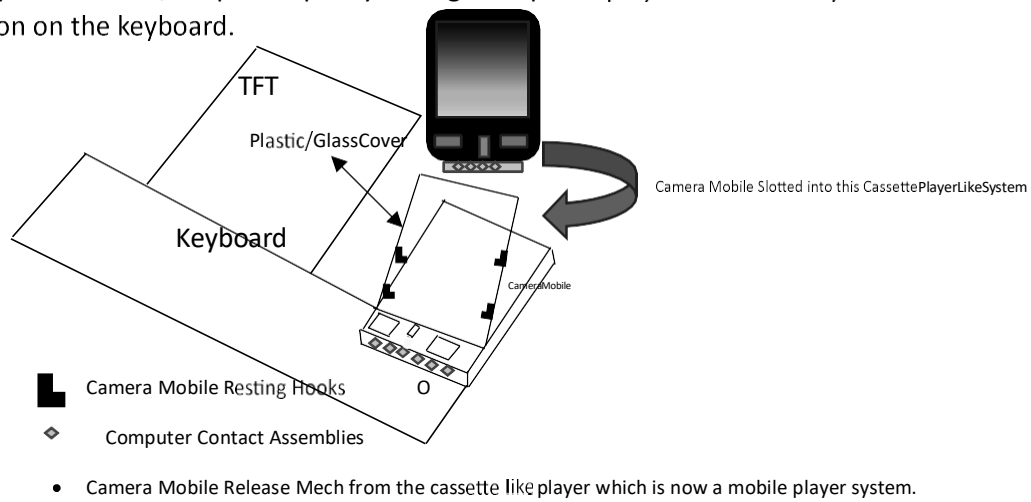

## FIGURE 35: Principle 2

Below is another way to slot the camera mobile phone in to the keyboard. From the Top of the camera mobile camera in to the slot leaving the left and right mouse button and multi control joy stick with mouse dial - exposed to manipulate with the TFT via keyboard. There will be a plastic glass cover in front of the mobile, which then releases hand pressured downwards. In principle 2 it is suggested the computer contact assemblies are on top of the mobile camera phone. (This is the perverse design)

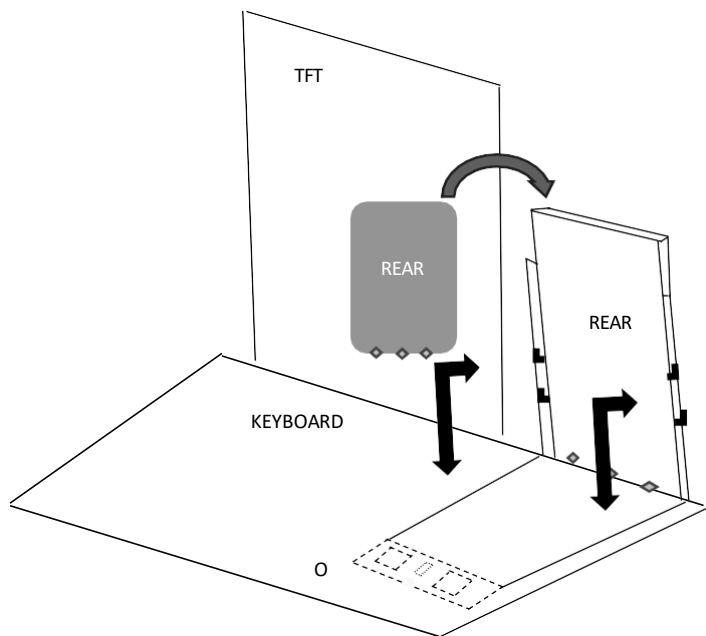

FIGURE 36:

This is an alternative design to the hand set with a single horizontal row at the top of the camera mobile phone with the speaker.

CONTACT ASSY ON TOP WITH SPEAKER



This will use Principle 2 Design- Cassette Plater Drive Mechanism to insert the mobile camera phone from the Top in to the slot and push down wards, exposing the mouse keys.

This is more effective as its like a Master Cardor Visa Card Being slotted into the ATM from Vertically top to bottom sides.

Well it might be more permissible to locate computer contact assemblies on top and bottom to match the above principle 1 and 2 designs whilst in factory mode.

This is a sample Vertical Camera Mobile Phone with Top and Bottom Computer Contact Assemblies to use both principal designs 1&2, of slotting the device into the key board.

FIGURE 37: TWO LOCATIONS OF CONTACT ASSY ON TOP AND BOTTOM



KEY



ComputerContactAssemblies(CCA)

FIGURE 38: PRINCIPLE3-THECAMERA

This can also be horizontal compact cameras, if you want to remove the usb cable/top cover, and even battery and charger then you for the following applies:

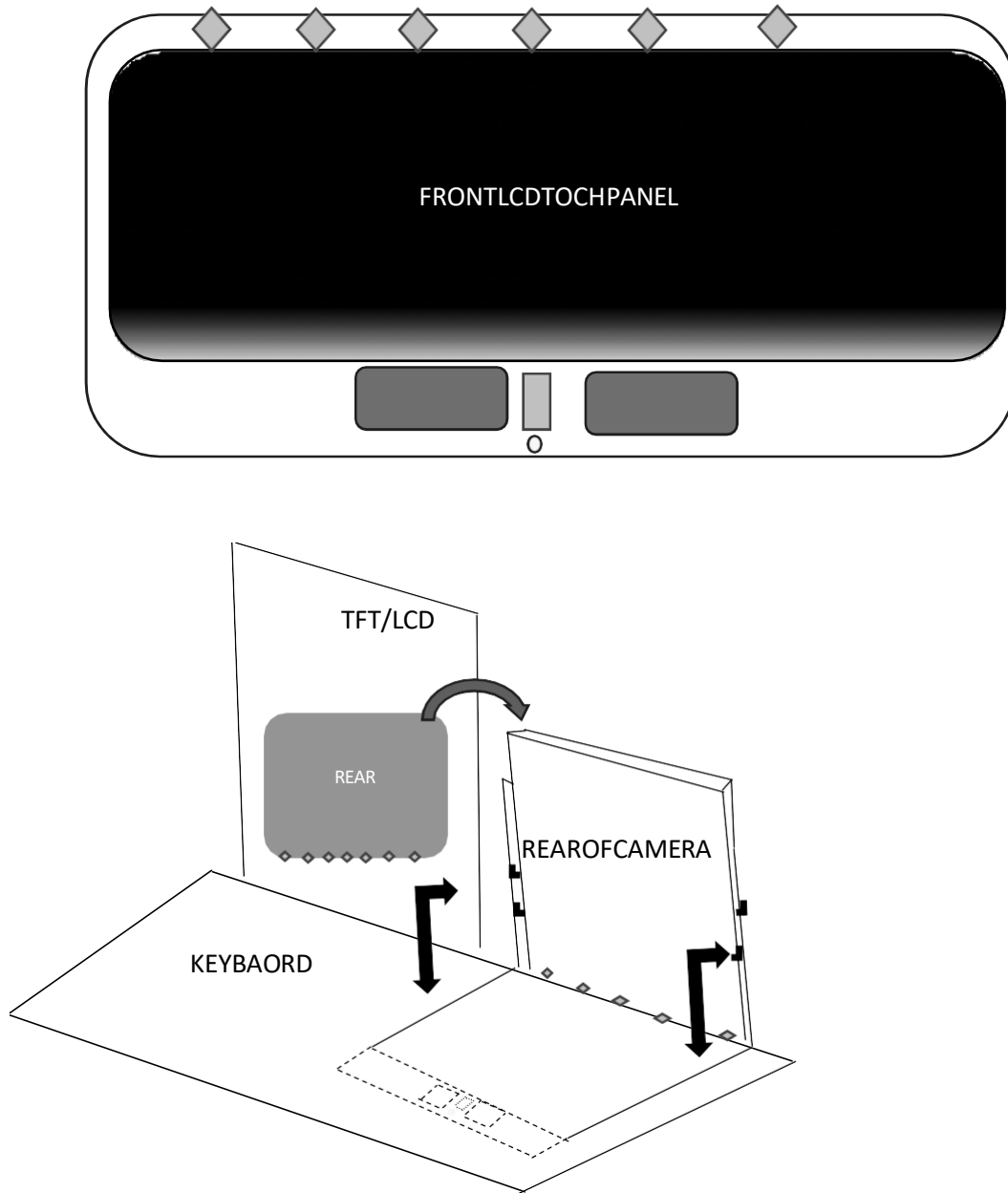

Just need to add measurements to the above design. There will be a flat optics on the front (NO LENSES). Touch panel on the rear and Solar Panel Rear with motion detection built in.

# EuroHiTech

sushil@eurohitech.com

FIGURE 39: BATTERY LESS CORDLESS VACUUM E CLEANER WITH CASSETTE MECH MOBILE SMART KEY PHONE DECK SLOT

The following designs show how to replace the battery pack of the Cordless Vacuum Cleaner with a mobile phone or a household automotive key. There after transfer all data back to the key phone on how much garbage was collected and how often cleaning was done. As be fore it use s the principle of cassette mech mobile docking key system with computer contact assemblies on both units the mobile key and cordless cleaner.

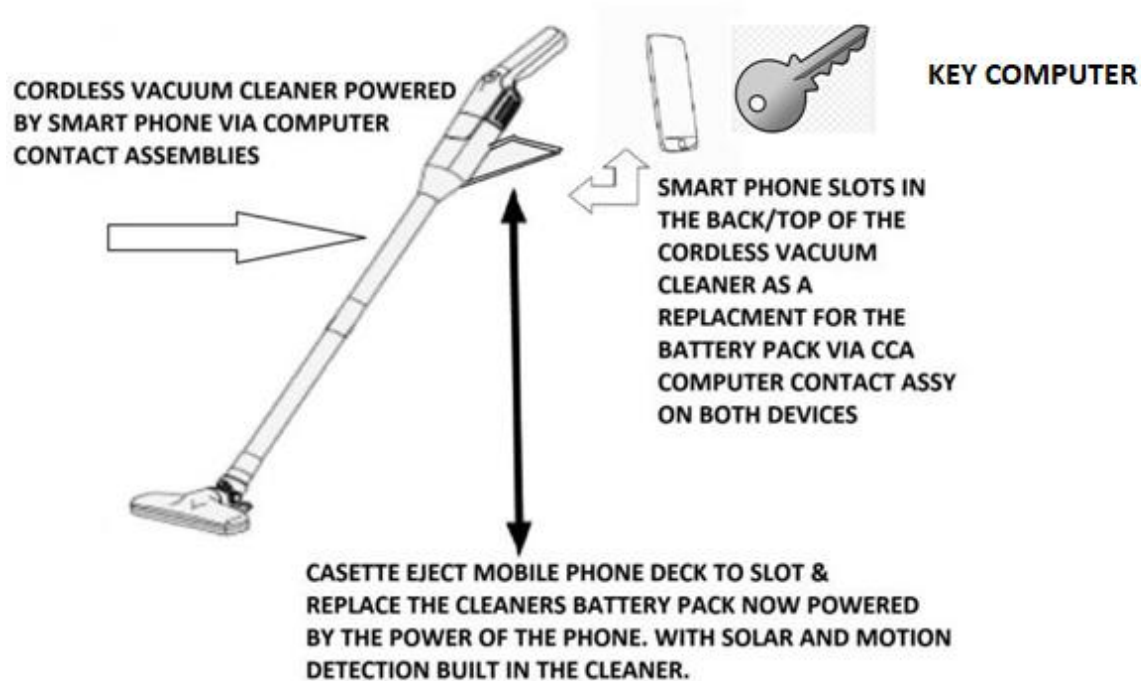

# EuroHiTech

sushil@eurohitech.com

**Figure 40: CASSETTE MOBILE PHONE COMPUTER KEY DECK OPERATION OF THE MICROWAVE.**

Here we have a microwave which all the buttons on the right hand side including the cross key pad and LED is replaced by cassette eject mech mobile KEY phone deck. Allowing you to slot the mobile phone KEY in to the microwave and then use the pad on the mobile KEY to operate the microwave.

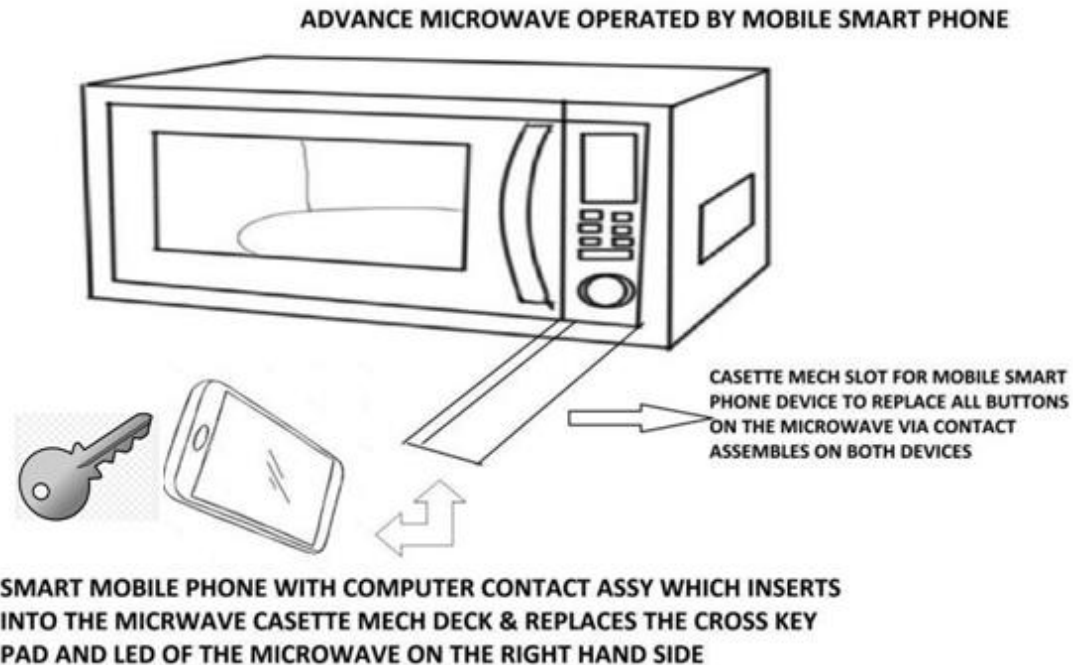

This could effectively lead to wire less devices and no need for 220v or plug socket on the vacuum cleaner and also on the microwave. A solar panel can be fitted on all devices with motion detection system allowing you to engage in power of these system. This could reduce fires and improve the quality of taste.

**FIGURE 41: SCOOTER DRIVER ARE YOU LOST !!**

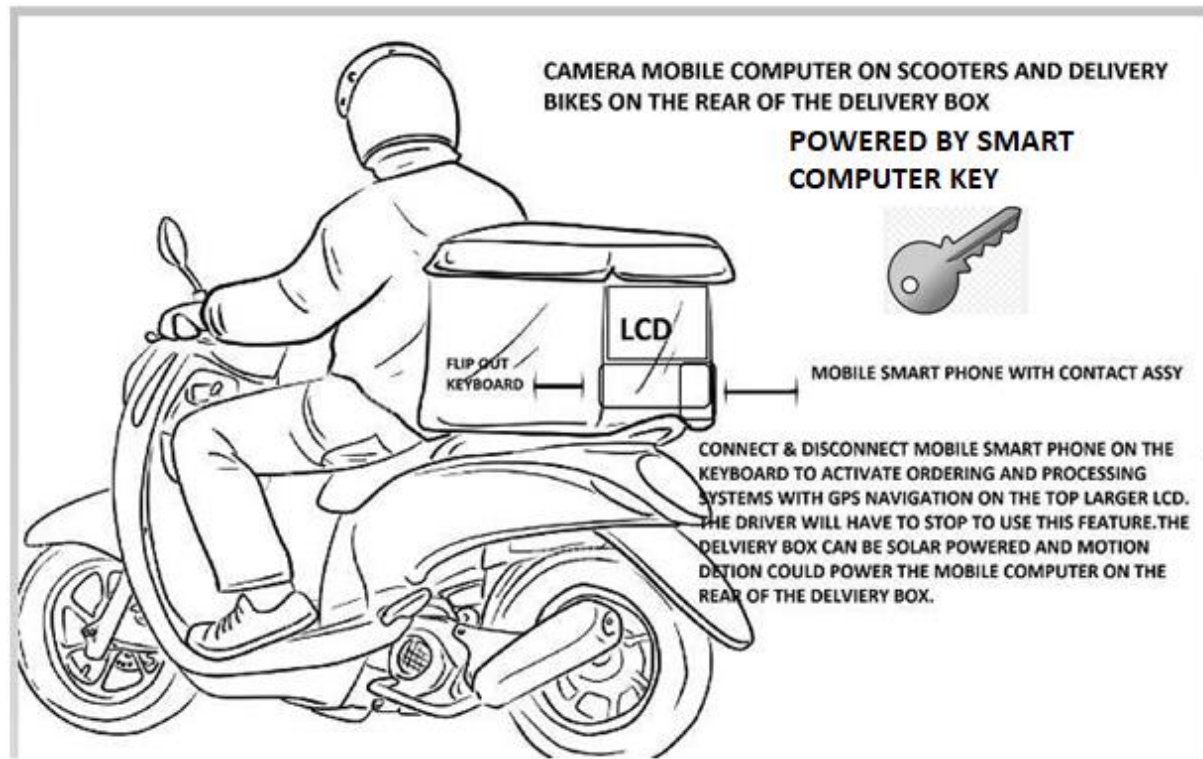

**CAMERA MOBILE COMPUTER KEY BUILT IN TO THE REAR OF DELIVERY BOX OF THE DELIVERY BIKE OR SCOOTER VIA SMART PHONE DOCKED IN TO KEY BOARD VIA CCA CONTACT ASSEMBLIES. THE BOX IS SOLAR POWERED AND POWERED BY MOTION DETECTION AND NO MORE CABLES. USE HINGES FROM LARGE LCD TO FLIP OUT KEY BOARD.**

**FIGURE 42: SMART COMPUTER KEY CHAIR ON THE REAR OF THE SEAT. APPLIES TO REAR SEATS OF CARS AND AUTOMOBILES.**

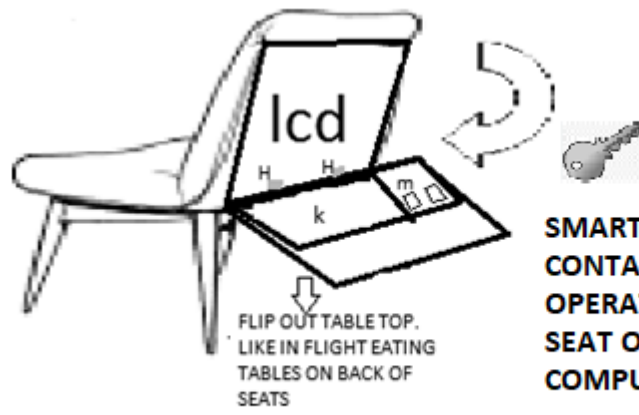

FLIP OUT TABLETOP.  
LIKE IN FLIGHT EATING  
TABLES ON BACK OF  
SEATS

**SMART KEY WITH  
CONTACTS ASSY TO  
OPERATE THE REAR  
SEAT OF THE  
COMPUTER CHAIR.**

# EuroHi-Tech

[sushil@eurohitech.com](mailto:sushil@eurohitech.com)

## **FIGURE 42: SMART PHONE MOBILE CAMERA KEY CHAIR WITH CONNECT AND DISCONNECT FOR M THE M MOBILE**

Here we have a built in LCD and Key board on the back of the chair, the LCD sits on the rear of the seat and a table top is pulled down to rest the Keyboard K. The K Key board flips out and MMobile Mouse docks in to side of the key board . The M Mobile (aswell as K the Key) is potable and you get what you see twice from M to LCD.

This is a state of the art design there are no cables, the table top flip out can be made of solar to power the computer. The LCD and Keyboard is connected via H hinge mech. Again the connection is via the contact assemblies on the mobile and keyboard.

# EuroHi-Tech

[sushil@eurohitech.com](mailto:sushil@eurohitech.com)

**FIGURE 43: MOBILE SMART KEY PHONE DIGITAL ALARM CLOCK**

Here the smart KEY phone with Contact assemblies docks in to the front of the LED LCD Display of the alarm clock, the alarm clock effectively acts as a case and replaced the front of the time LED with the front of the mobile KEY phone which there after displays the time and alarm clock via a built in intranet facility. The mobile KEY ejects in to the front and release s out via the release mech on the side of the alarm clock.

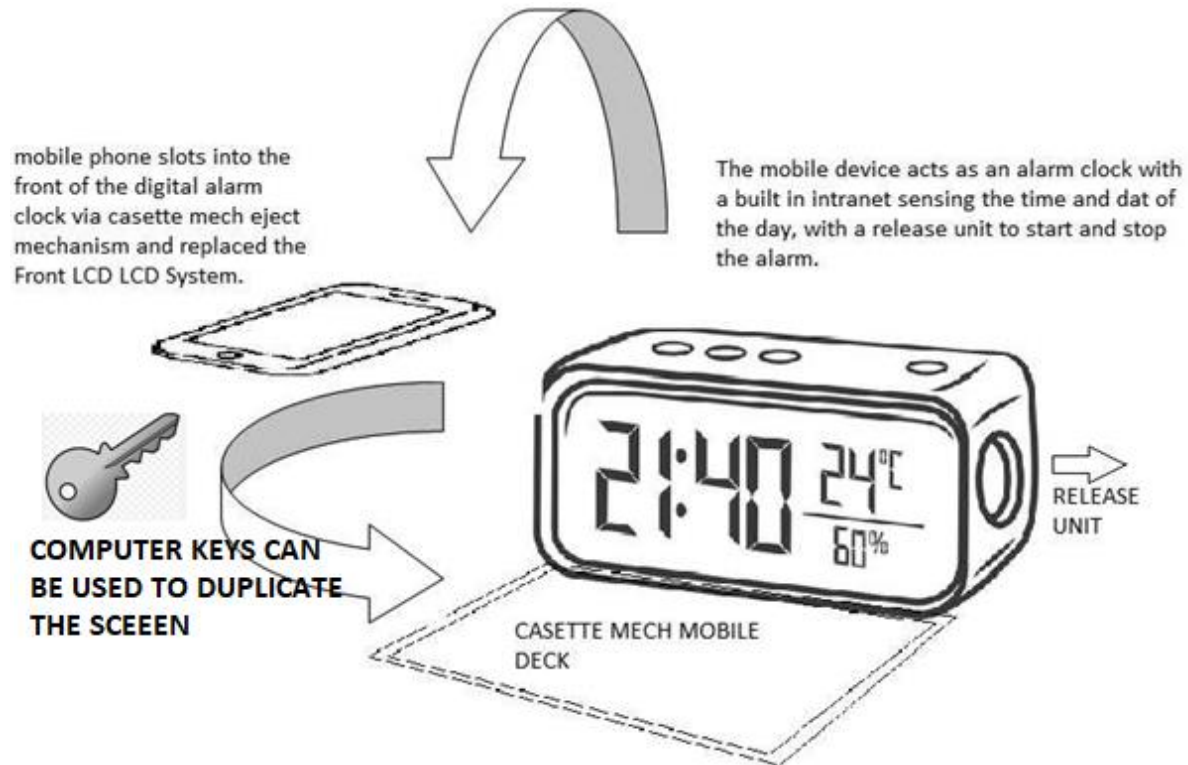

There is no cable and the power of the KEY phone sends power to the alarm clock to activate it, and there after no cables and no plugs and no batteries may not be required.

# EuroHi-Tech

[sushil@eurohitech.com](mailto:sushil@eurohitech.com)

## **FIGURE 44: MOBILE WASHING MACHINE WITH NO CABLES POWERED BY A COMPUTER KEY SYSTEMIA.**

Here most of the switches on washing machines are on the top front of the washing machine. And you put the cloths to wash in to the front of the machine.

Here all the switches are replaced by the M mobiles KEY smart phone with contact assemblies and docked into the machine like a cassette mobile deck KEY system as researched previously. There after the top can be made on Solar Panel or even there after replaced with a large TFT SCREEN so you get what you see from mobile KEY you get twice on the upper Tilt LCD TFT PANEL .Here motion from the drum and recharge the power pack in the KEY mobile and washing machine, all power from mobile device and all function can have touch panel from Mobile key and or Large TFTS SCREEN PANEL with reverse Solar Display for power pack.

There is only a water supply cable and no other 220V voltages its effectively mobile and futuristic.

You can put a full mobile KEY computer on the washing machine replacing the cross key pads and built in functions with an eject mech cassette key mobile deck. The computer contact assy(CCA)play an unequivocal part. There are no more switches and buttons on the washing machine, the mobile phone operating system actions the behavior on the machine.

THIS UNIT IS NO LONGER REQUIRED AND CANBE DISCONTINUED.YOU CANZOOM INTERACTION WHERE STAFF MONITORS THE WASHING MACHINE AND UP DATE YOU WHATSUP.

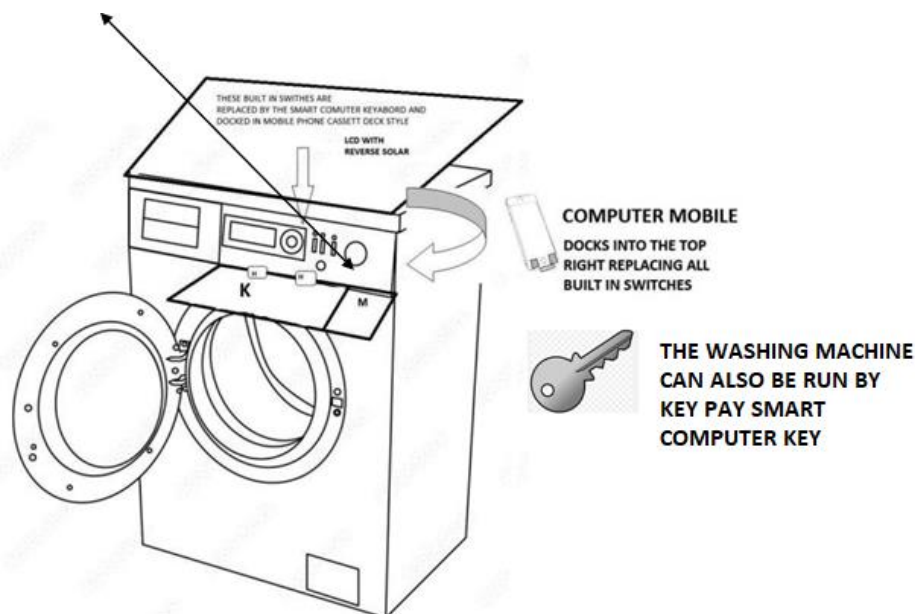

# EuroHi-Tech

[sushil@eurohitech.com](mailto:sushil@eurohitech.com)

**FIGURE 45: MOBILE COMPUTER OVEN WITH NO MORE KNOBS OR BUILT IN BUTTONS**

The grey line indicated there placement of built in knob s and buttons and know the LCD of the mobile KEY replaces everything along with the key board and you have a large REAR TFT Screen displaying all the cameras information of cooking. The mobile cooks every thing on timers and programmes. This use s contact assembleies for connection and is connection.You can cook and play and answer the KEY phone or let some one cook you around the world viaw if l and get top tasting food.

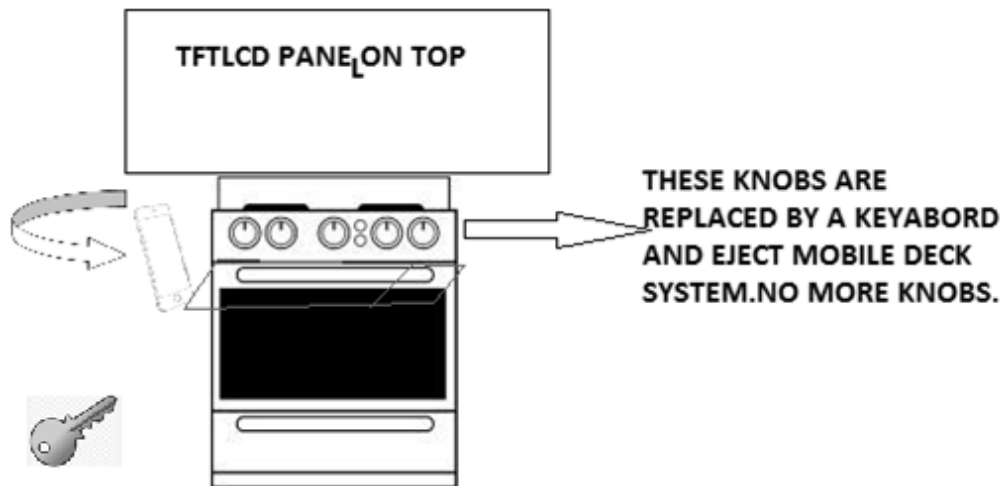

**THE DISPLAY OF THE COMPUTER MOBILE KEY REPLACES THE ELECTRONICS ON THE COOKER.**

# EuroHi-Tech

[sushil@eurohitech.com](mailto:sushil@eurohitech.com)

**FIGURE 46: COMPUTER TOASTER WITH MOBILE KEY PHONE EJECT MECH DECK SYSTEM.**

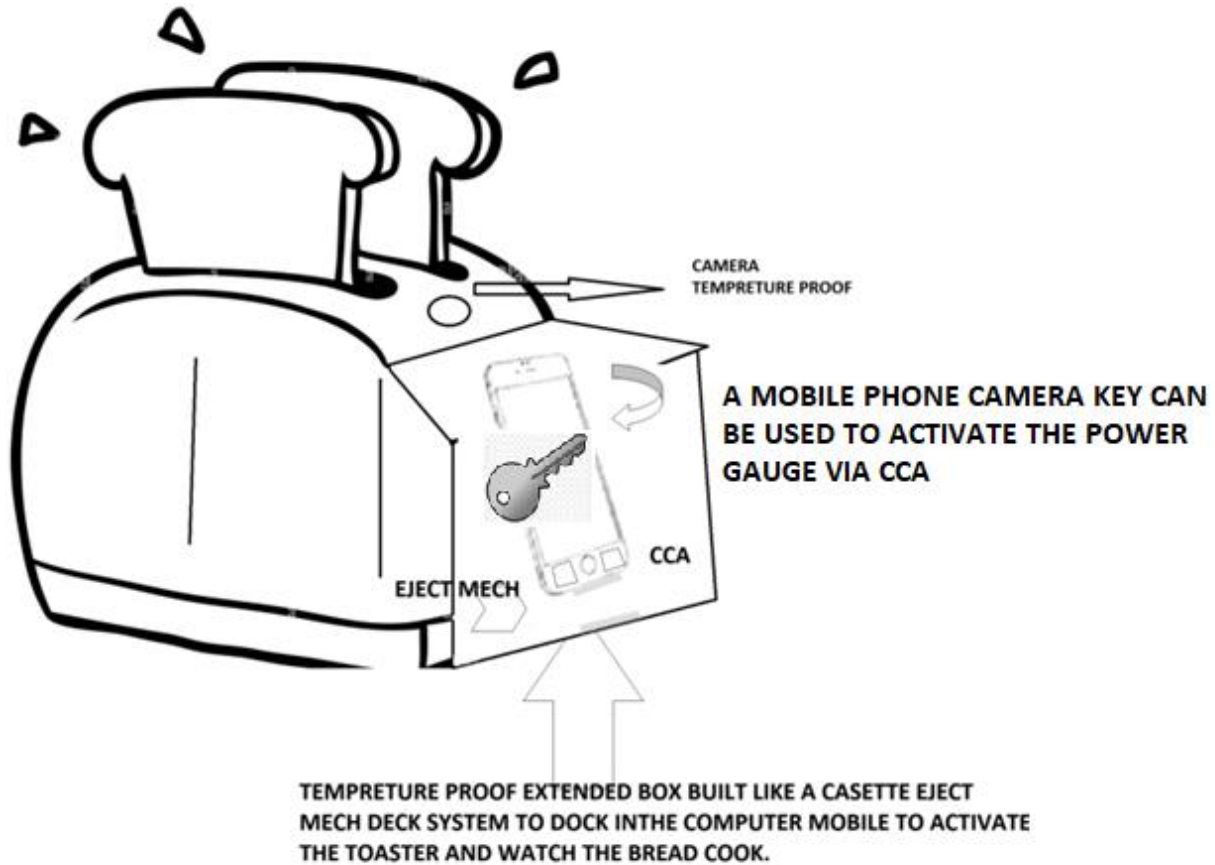

Here the mobile KEY phone is docked in to the toaster this activates the heat via power charge from CCA computer contact assy. The PCB then toasts the bread and is watched on the camera then on the to display of the new type mobile phone KEY system. There is an eject mech and this could be fire proof and make toast taste delicious with a program on the KEY phone to cook the toast how you like and timer. There may be no cables , with solar panel finish on the side s of the toaster and take the toast e r anywhere e with you even Glastonbury camps. The mobile KEY determines the power ,could be electric heat.

# EuroHi-Tech

[sushil@eurohitech.com](mailto:sushil@eurohitech.com)

**FIGURE 47: Computer KETTLE WITH MOBILE KEY DOCKING SYSTEM AND NO 220V**

Here we have mobile kettle, it uses the power of the mobile key program to activate the kettle and heat up the water to execute the amount. The principle of cassette mech mobile key deck and computer contact assy and bottom pcb is essential.

*Eject mech insert of key mobile phone, the power of battery on phone, power s the kettle battery replacement. (Ejectmech)*

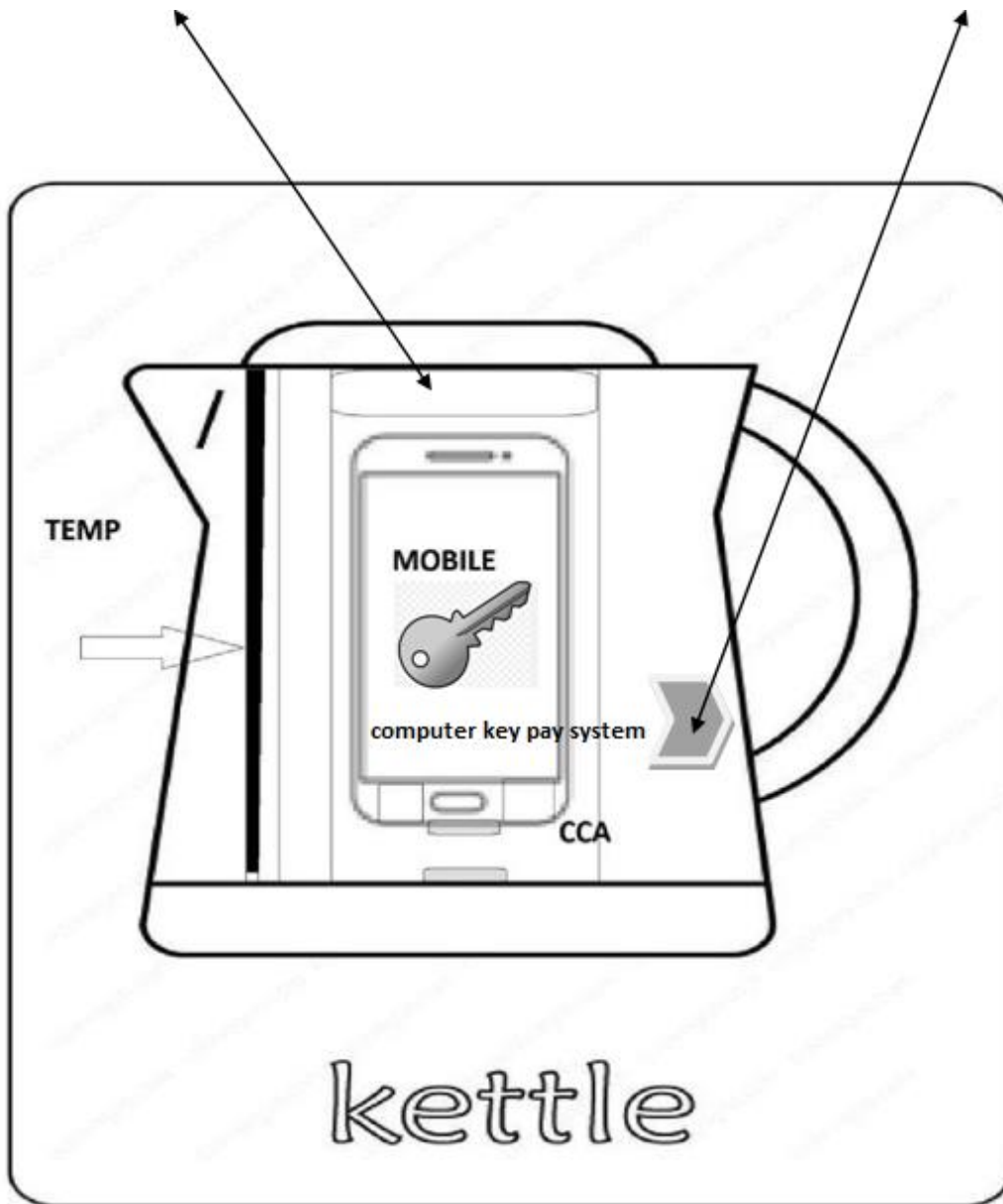

# EuroHi-Tech

[sushil@eurohitech.com](mailto:sushil@eurohitech.com)

**Figure 48: IGNITION START AND STOP BY COMPUTER OR MOBILE DEVICE ON THE FRONT OF THE STEERING WHEEL/NO MORE DASH BOARD.**

There is no more digital display on the scooter, this is replaced by my mobile key phone pay phone design with CCA Horizontally. And All data will be on intranet of the bike to start and stop and to review all data of bike's performance with GPS and all other features. A Computer Pad can also be used. Here the LCD of key device is built in to the steering wheel of the car or bike. A keycode can start and stop the car. A wifi radio signal can remotely stop the car by police if speeding or they can use stack systems or plus networks to manipulate the driver.

## SCOOTER DRIVERS VIEW FROM THE FRONT OF THE SCOOTER

HERE THE DIGITAL DASH BOARD IS REPLACED BY A REMOVABLE DOCKING IN EJECT MECH CASSETTE DECK HORIZONTAL MOBILE PHONE SYSTEM

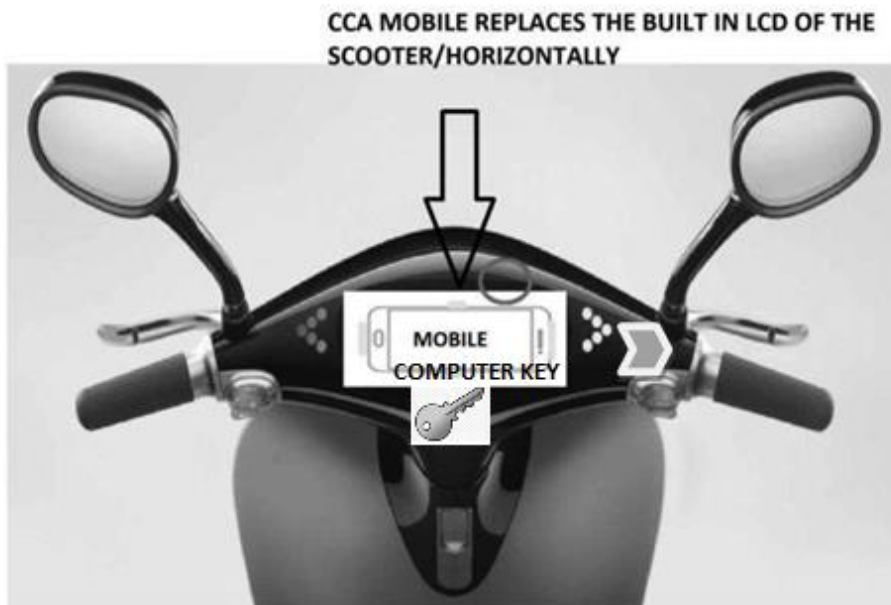

My full fledged computer KEY can be built in on Larger bikes. The digital dash board is replaced by disconnect and connect mobile phone system.

KEY



eject mech of mobile KEY camera device.



Cca computer contact assy on bike and phone

# EuroHi-Tech

sushil@eurohitech.com

FIGURE 49: DIGITISED LETTER KEY MOBILE BOX COMPUTER

Most Letter boxes by Royal Mail are 200 years old or even older. They need renewing. Here is a precise method of replacing or in putting new Letter Boxes up to Medium Parcel in society.

DIGITISED LETTER BOX UPTO MEDIUM PARCEL, WHEN M MOBILE DOCKED IN A SMS/EMAIL/WHATS UP TRACKER IS SEND VIA PROGRAME TO CUSTOMERS MOBILE. THE KEYBOARD CAN BE ON TOP TFT AS WELL AS BELOW.

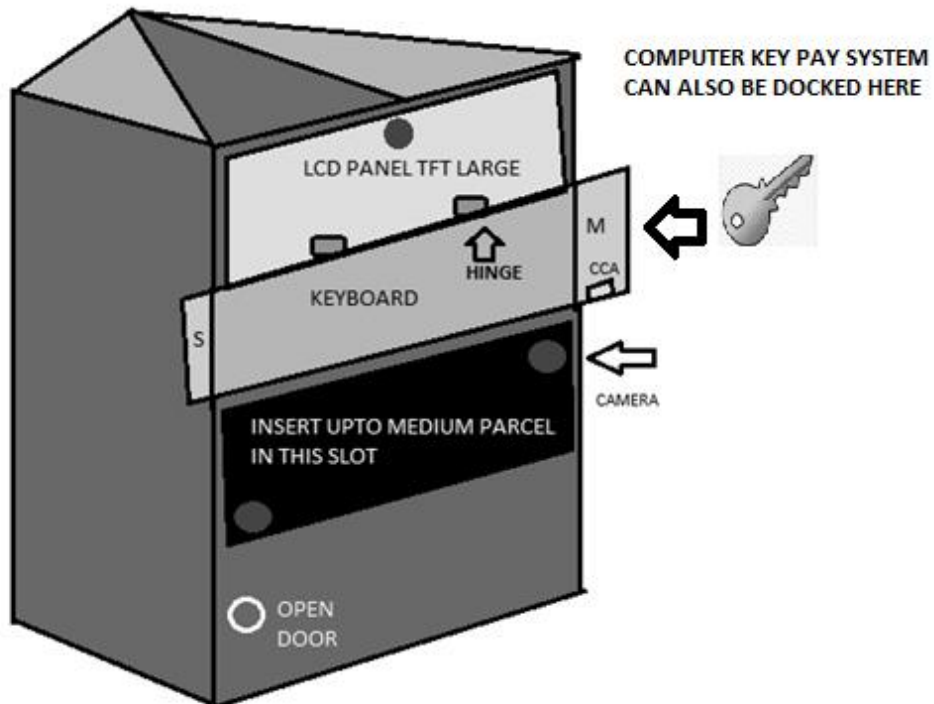

WITH TEAM VIEWER A STAFF CAN ACCESS THE CAMERA AND WATH THE GOODS BEING INSERTED IN TOLETTOR BOX. IT SHOULD BE LARGE PRINT SHIPMENT BILLS.YOU SCAN EACH ITEM IS ED BARCODE AND A TRACKER IS PRODUCED VIA EMAIL AND SMS OR KEY SMS WHEN YOU LOG IN TO THE SYSTEM.

You CAN have a solar powered roof to p applying power to the computer network sand systems. The Computer Contact Systems again a principle of use.

# EuroHi-Tech

sushil@eurohitech.com

FIGURE 50: STATE OF THEART STANDARD NETWORK MOBILE TELEPHONE BOOTH/ BOXCOMPUTER WITH COMPUTER PAY BY KEY

BT DESIGN ARE PRETTY ORDINARY THEY LACK PRINCIPLE.HERE SHOW TO TAKE A LOOK AT NEW CONCEPT DESIGNS.

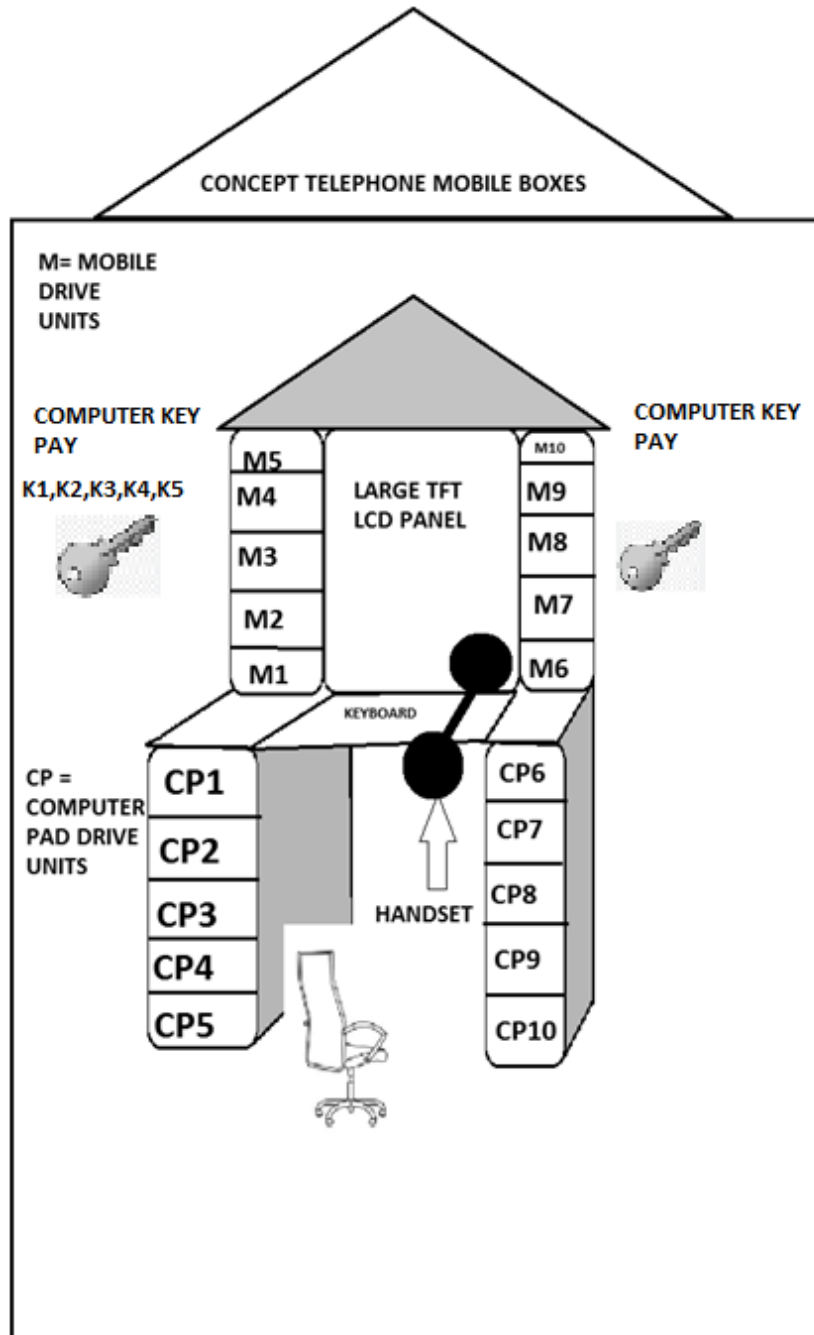

Once the KEY PAY mobile is inserted into the drive it automatically connects to the programme and you get n to 20 devices being located by the program on to the larger tft. You use a master phone on the middle of the key board toping messages out.

# EuroHi-Tech

sushil@eurohitech.com

**FIGUFRE 51: NEW TYPE TRAFFIC LIGHTS**

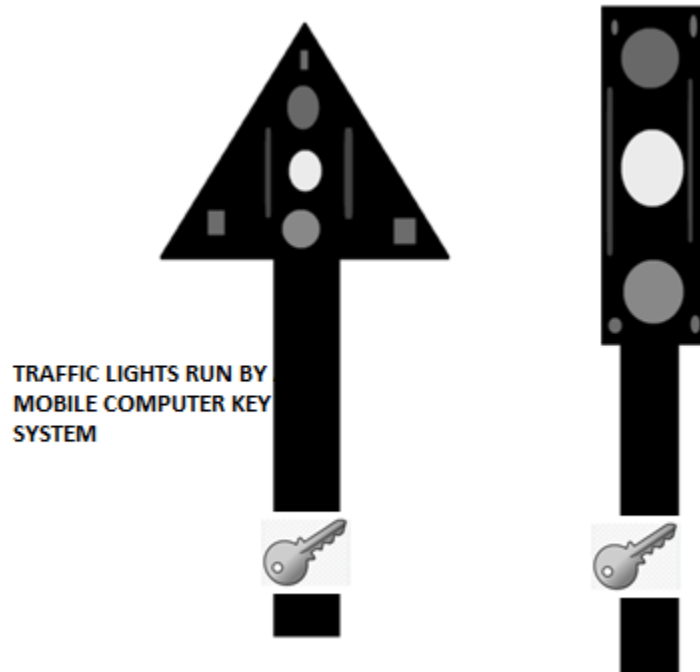

TRAFFIC LIGHTS RUN BY  
MOBILE COMPUTER KEY  
SYSTEM

**RED YELLOW AND GREEN ARE TRAFFIC WAITING LIGHTS**

**BLUE IS TWIN FLASH BUILT IN TO THE BODY OF THE LIGHTS-MORE FLASH UNITS CAN BE ADDED TO THE BODY**

**THE GREY IS SPEED CAMERAS TO DETER SPEEDING AND ISSUE FINES STRAGHT TO THE MOBILE DEVICE OF THE OPERATING VEHICLE.**

**ONE TRAFFIC LIGHT IS TRIANGULAR SHAPED (LEFT)**

**ONE TRAFFIC LIGHT IS RECTANGULARLY SHAPED VERTICLE. (RIGHT)**

**BOTH POWERED BY A KEY**

**FIGURE 52: KEY PHONE ATTACHED TO A TRIMMER FOR AUTONMOU STRIMMING WITH NO CABLES AND NO BATTERY, THE SOLAR POWERED PHONE WITH MOTION DETECTION ACTIVATE S THE TRIMMER VIA THE PHONE POWER SYSTEM.**

This is idea lfor hair dressing and is cutting costs as well as cutting hair. This can then dock into the computer system as described as the standalone to collect payments provide receipts and pay tax. This is effectively a KEY mobile phone trimmer or trimmer key phone.

**Here we have asmart mobile phone which sleeps/docks into the front side of the trimmer via contact assemblies. It allows autonomoua power from the hand set to activate the trimmer. There are 220V or there are no cables**

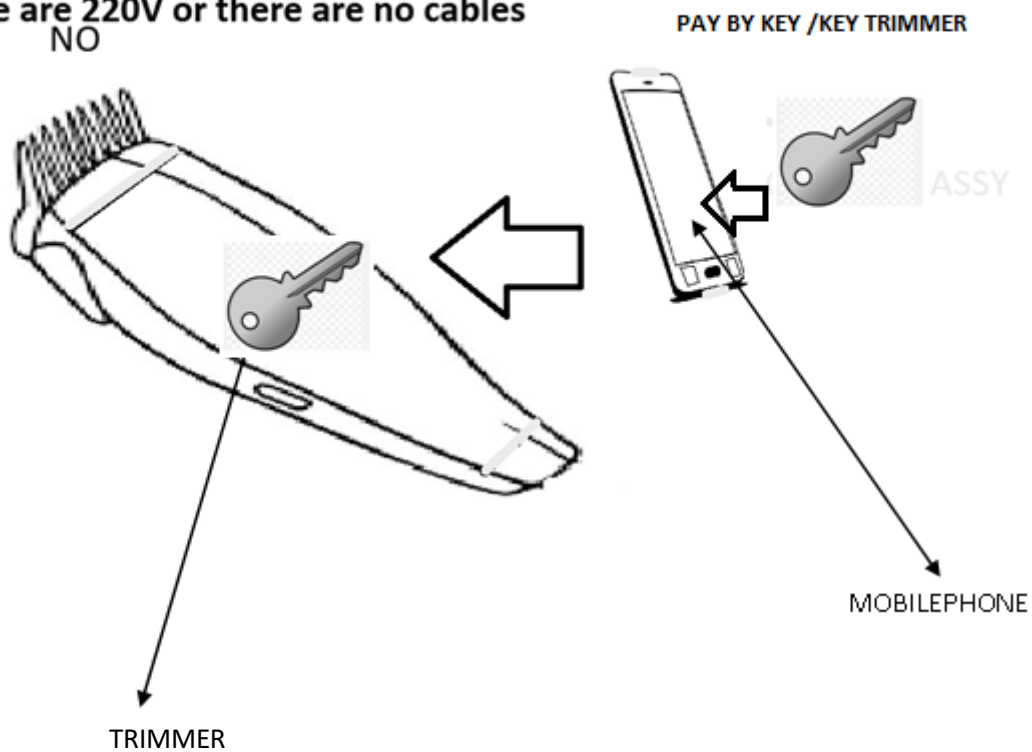

**FIGURE 53: FULLY AUTOMATIC IRON WITH NO CABLE AND NO 220V POWERED AUTONOMOUSLY BY THE COMPUTER KEY MOBILE PHONE WHEN DOCKED INTO THE IRON. AIR ON KEY PHONE OR KEY PHONE-IRON.**

Again the Smart Mobile Phone Docks into the Center of the IRON via Contact Assemblies and replaced the Dial Unit on the iron to be functional on the touch panel of the mobile phone. There is no cable and no 220V it is autonomously powered by the phone power system of solar generation, pumping temperature automatically into the iron.

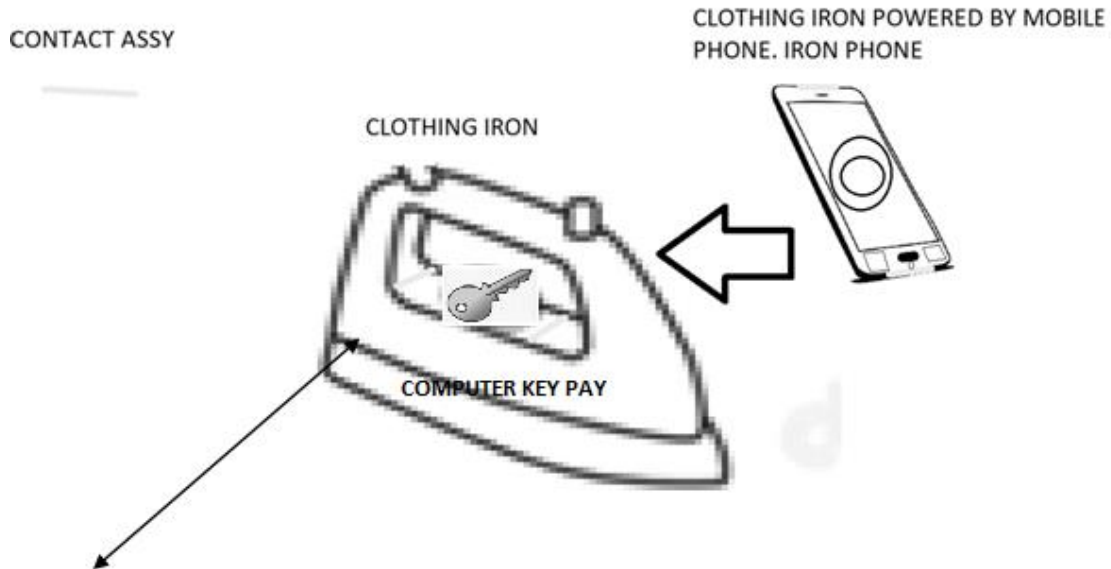

**SOLAR PANELS ON THE IRON**

Once KEY mobile is removed it can give data about iron usage etc on the computer standalone as described in previous pages. The iron could have a built-in intranet and panels of solar on the side. Every time it has motion it adds power to the KEY phone both ways.

**FIGURE 54: FAN OPERATED BY A MOBILE KEY CAMERA PHONE–KEY FAN PHONE**

Here we have a standard mobile camera phone with contact assemblies on the top and or on the bottom. There are two types of Fans, one desk fan and floor standing fan.

The on off switch and control assy of the fan is replaced by a key mobile phone. So effectively there is no on off switch and no dial to adjust the speed of the fan. This is all done by the settings on the key mobile camera phone.

The speed of the rotors recharges the phone and keeps the power oscillating via motion charging technology. There are no batteries and no cables. The fan is run by the power and settings of the key phone on the fan.

The fan uses energy from the mobile to activate it.

**FAN PHONE**

A FLOOR FAN ACTIVATED BY MOBILE CAMERA PHONE WHICH DOCKS INTO THE FAN VIA CONTACT ASSY, & REPLACED CONTROL PANEL OF THE FAN

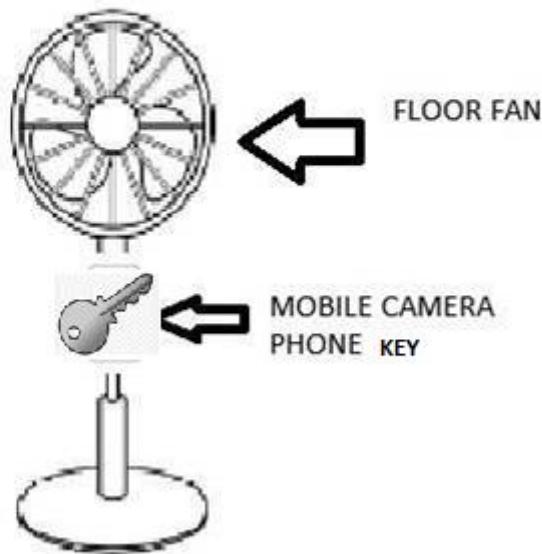

**Figure 55: REMOTE CONTROL WITH BUILT IN MOUSE**

Here we have a standard remote control with a left and right button at the bottom of the control with a dial assembly in between and a cursor matt or a multi controller joy stick under neath the dial assy.

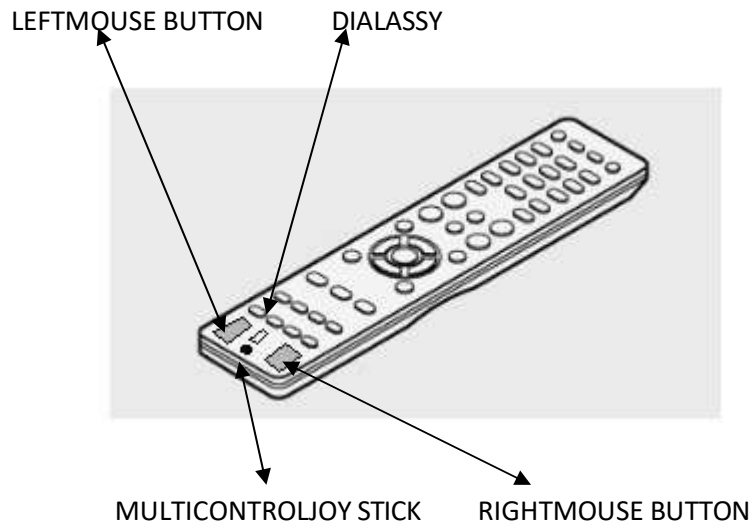

CLAIMS FOR COMPUTER FILE NUMBER: GB2510034.8

The claims i would like to make are in numbered order:

- 1) First there is no separate mouse. The mouse is built into the camera mobile phone, so effectivily the mouse gets discontinued.
- 2) There are no USB's. The camera mobile phone consist of Contact Assemblies Top and Bottom or Side to side of the handset device. The contact assemblies are generic and used to transfer data from the Lens Auto Focus to the DSLR SLR Main PCB via images onto LCD and sound and movement. This feat of technology has never been achieved to replace USB.
- 3) With multiple flash units built into the body, there is not Top Cover or Upper Cabinet in the DSLR Camera. Hence forth allowing for greater picture quality and reduce the ubiquitous error codes associated with pop up mechanisms. There is not hot shoe unit or hot shoe plate, you can put built in flash units into the body of the compact camera hence discontinue speedlite flash gun.
- 4) Solar and Motion Detection Rear Cover. Here there is not battery and charger in the camera, its all powered by a complete solar back and motion technology like in Swiss watches.
- 5) No CMOS, this is very expensive to produce and Lens Unit causes errors with a slight knock so now there is emphasis in built in lenses.
- 6) No cables, the contact assemblies allow the handset to be pushed in to the keyboard or slept on the keyboard with a release mechanism. This allows for efficient data transfer and systematic mechanisms of movement.
- 7) The memory card slot pcb gets discontinued now built in memory processors are used.
- 8) You can have a table top computer in every cafe or every table. There is no CPU central processing unit or Lap Top. The computer can be coloured or shaped in any method and the hand set acts as a operating system which is duplicated on the upper TFT and all files are saved directly on the hand set.
- 9) You can have stack systems and plus network drives.
- 10) You can have matrix of computer systems expanded from n squared to infinity.
- 11) You can replace M Mobile with K a house hold Key which can be computerised, and payment gateway promoted.
- 12) No 220v-240 V No plug. The Mobile of Key with contact assemblies replaces the cable and the hand set or the key acts as a power source connected direct to appliance.
- 13) Keyboard vibrotronics to charge the hand set. The vibration of the keyboard can autonomously charge the hand set.
- 14) No CPU and No Lap Top. This system sues two principles 1) What you See is What you get Twice. WYSIWYGT & 2) Casette Mech Dock Handset Key Mechanism to manipulate data.

FIGURE 1: PAY BY KEY

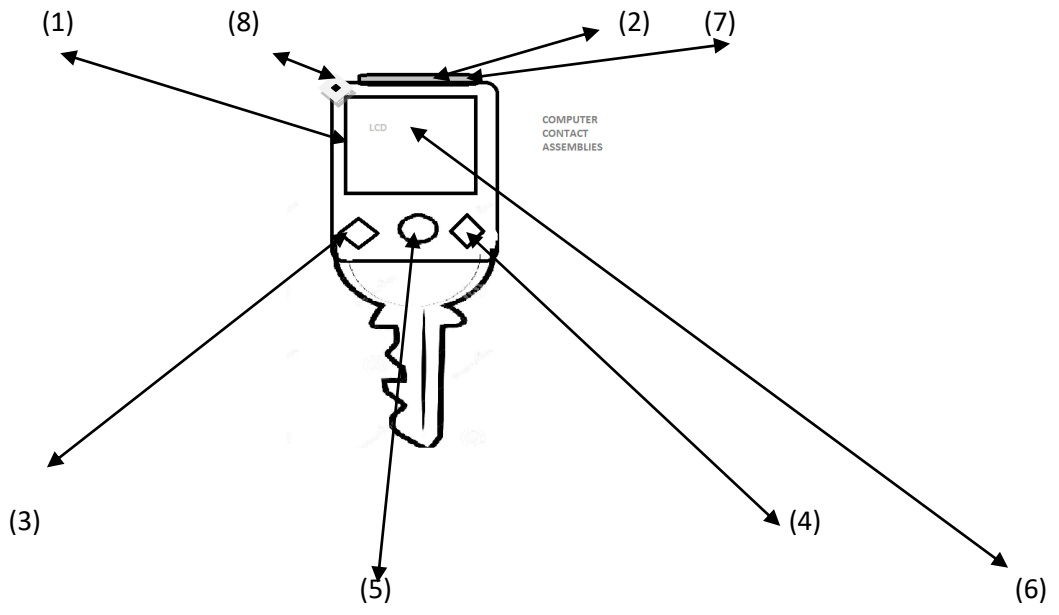

FIGURE 1 : KEY

- 1) DIGITAL PCB INBETWEEN THE CASE
- 2) OPTICAL CAMERA
- 3) PAYMENT SENSORS (DEBIT)
- 4) PAYMENT SENSORS (CREDIT)
- 5) CIRCLE STRIP OR SWAB FACILITY WITH PAYEMNT GATEWAY
- 6) ACCOUNT BALANCE LCD
- 7) COMPUTER CONTACT ASSEMBLIES TO DOCK /SLEEP ONTO KEYBOARD CONNECTIVITY
- 8) AUDIO PORT FOR LISTENING TO MUSIC AND TRANSFERING DATA TO EAR HEAD PHONES.

FIGURE 2: Pay By Key with Networks.

---

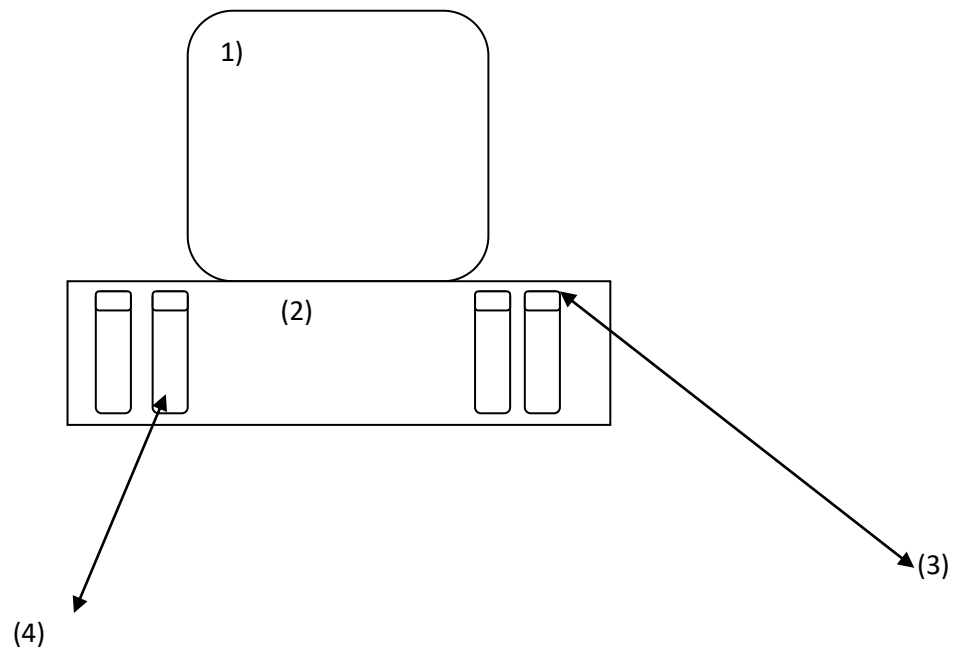

FIGURE 2 KEY:

- 1) LCD UPPER TFT
- 2) KEYBOARD
- 3) CONTACT ASSEMBLIES
- 4) X 4 PAY BY KEY

## DESCRIPTIONS

Here Figure 1. we have a normal key turned into a payment gateway to make transactions to purchase food and beverages and even to any transaction which credit or visa or master card is able to do.

This uses sensors in key and a swipe swab facility allowing payment to be credited (4) or debited (3). You can add a pager on to the device to even receive messages or send out messages using the computer payment gateway system.

This will transform markets and excel pass mobile payment systems. It is light and easy to carry and the key can be turned in to a pay by computer key using contact assemblies at the top of the key device. The contact assemblies (7) are found in DSLR Camera Bodies which allow the Lens To Communicate to the Body VIA Auto focus thereafter to the PCB.

## ABSTRACT

A Key is turned into a payment method. Here we have a LCD and PCB and Contact Assemblies combined with sensors to make payment for goods and services and all payment transactions.

You can credit or debit the amount using buttons on the key. You have LCD display which shows the account balance. You swab or swipe the key to debit from account and is deducted on master accounts.

You can have stack systems on top of each key or plus network drives and can act as security for all transactions. It uses contact assemblies to dock into the keyboard and act as a computer without the Central Processing Unit CPU and Laptop.

## CLAIMS

You effectively are using the average key to purchase goods and services with no visa or master card. This is alternative payment gateway which can be turned into a Powerful Bankers computer. You can add money from the key or debit money from the key. You swipe swab and go. Or even Click the finger print recognition button to confirm payment. You can chat and listen to music with the key via external audio ports. A camera can be built into it for facial recognition.



ABSTRACT FOR COMPUTER FILE NUMBER: GB2510034.8

If you look in all offices the tables are blank and do not use a table top computer and the mouses are separate feature. The hand set devices do not use the principle of Contact Assemblies found in SLR DSLR and Mirrorless Cameras to wipe out USB. If you look at keyboards they don't have a separate release mechanism to sleep or dock the Hand Set into the keyboard.

Thereafter no need for cables.

Most hand sets if not all have a separate cable to charge the phone and a cable to power supply the handset. They do not use complete cover solar backs or motion detection technology. There are no networks stack systems and plus networks on infinity computer systems.

This is what this document is trying to emphasis the use of built in mouse in to the hand set and the use of computer contact assemblies therefore replacing the USB and thereafter using the feature of solar and motion technology so no use of plugs ports or cables.

This level of features is new and robust and transforms the handset into highly efficient mobile camera computer.

At least the present systems are too big and heavy for mobility and cost too much. My system customises, mechanises and systemises the computer into an effective mobile system with camera operation and all the other features.

Perversely all systems are inadequate and incomplete and require continuous charging, this principle cuts time and is an effective art in communication.

You can have table tops or mobile computers with the principle of what you see is what you get twice and all data is transferred on to mobile mechanism which acts a sole operating system to function from.

**EURO HI –TECH PHOTOGRAPHIC SERVICES LTD MOBILE CAMERA COMPUTER  
PHONE DESIGNS-NO USB, NO CHARGER CABLE WITH BUILT IN MOTION  
TECHNOLOGY AND VIBROTRONICS ON KEYBOARD WITH SOLAR BACK  
COMPLETE.**

**BLISS**

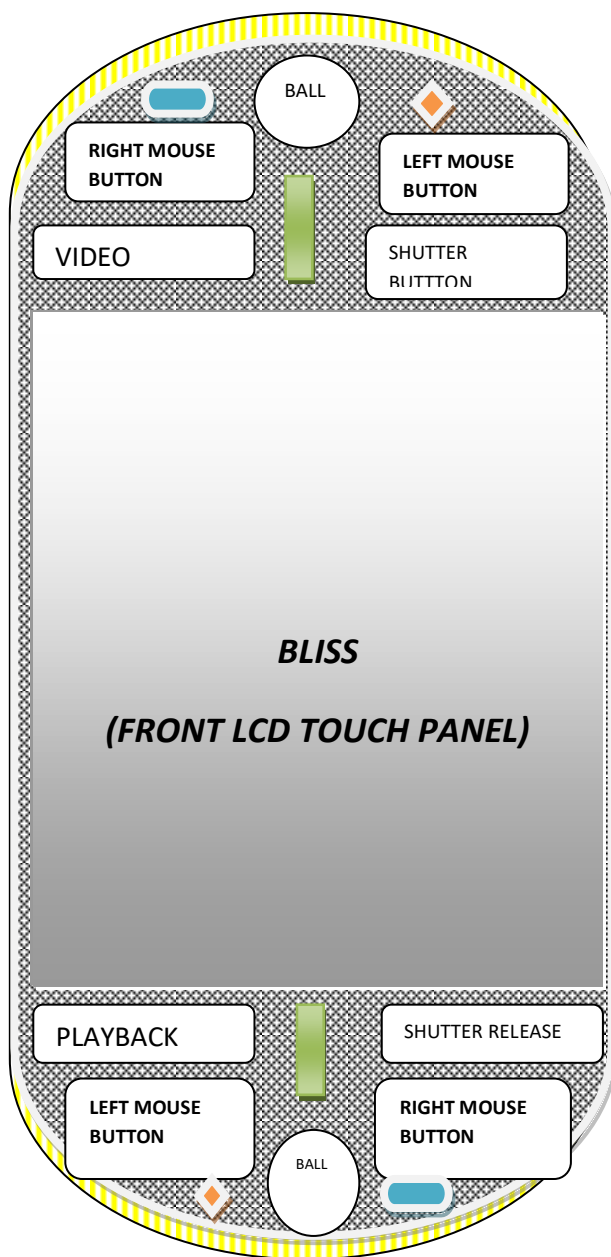

KEY:



FLASH UNIT



CAMERA



DIAL ASSEMBLY



CONTACT ASSEMBLIES WITH SPEAKER AND MICROPHONE TOP AND BOTTOM

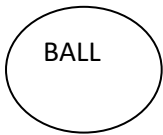

ROLLERBALL MOUSE WITH DOUBLE CURDER OR MC JOYSTICK FOR CURSER

# SEDUCTIVE

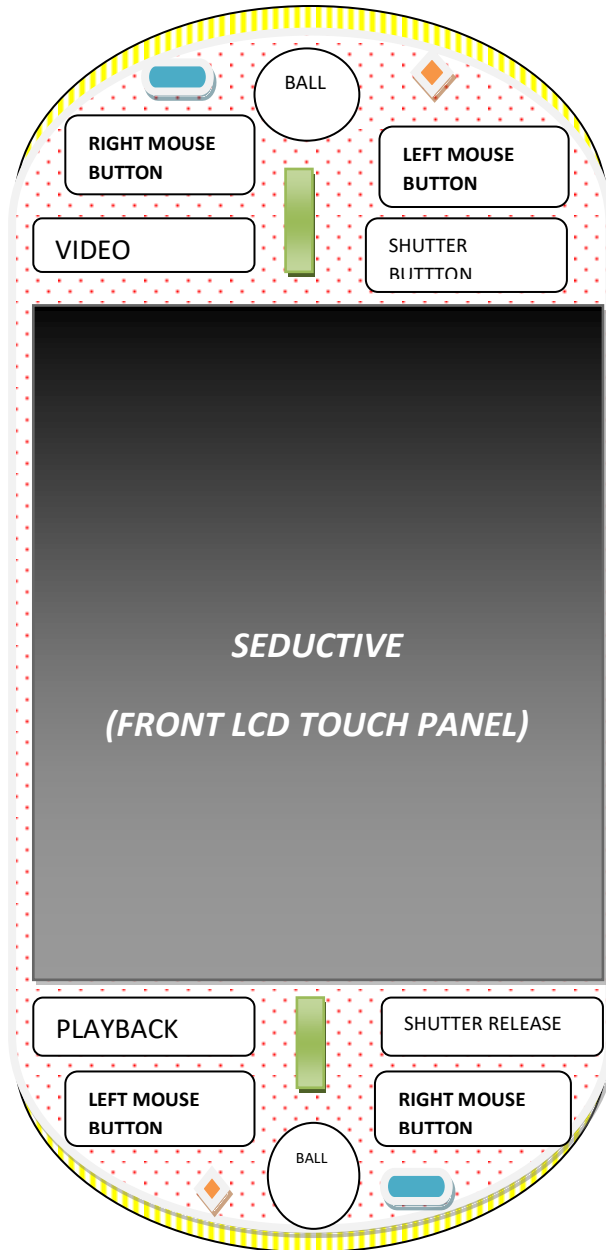

KEY:



FLASH UNIT



CAMERA



DIAL ASSEMBLY



CONTACT ASSEMBLIES WITH SPEAKER AND MICROPHONE TOP AND BOTTOM

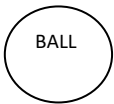

DOUBLE CURSER CONTROLLER, ROLLERBALL MOUSE OR MULTI CONTROLLER JOY STICK

# EXCELLENT

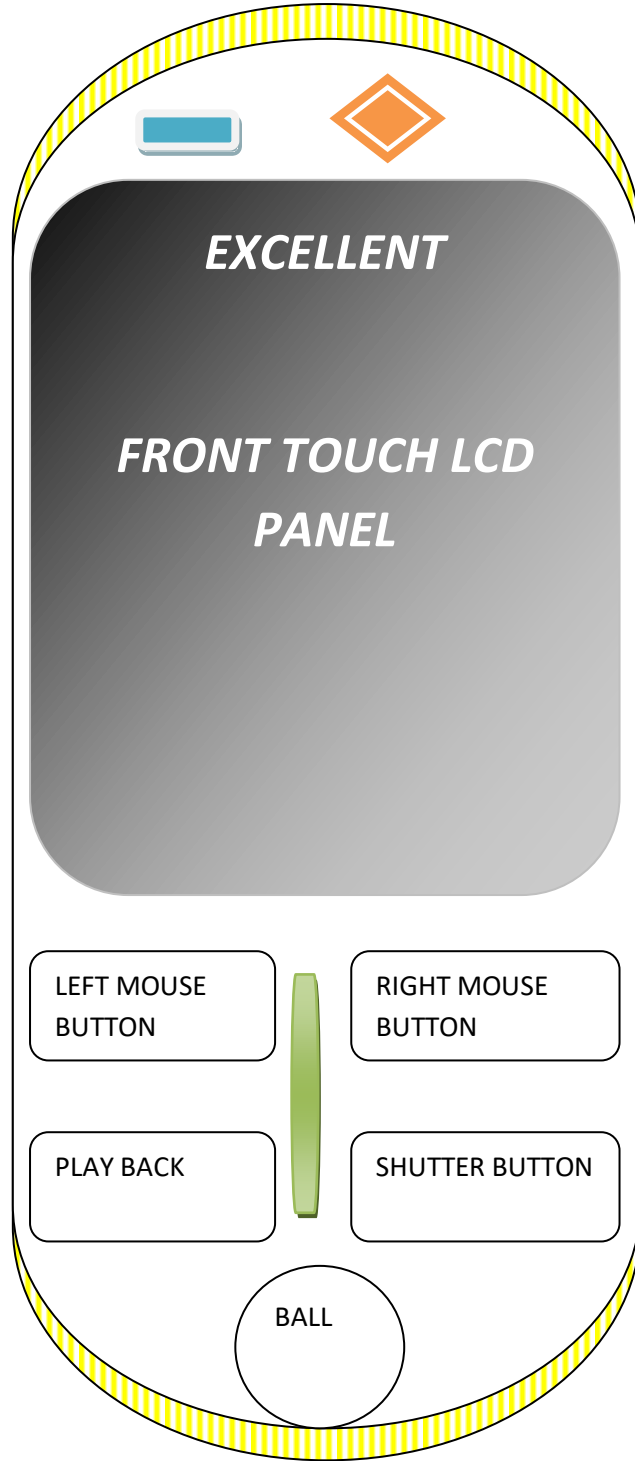

KEY:



FLASH UNIT



CAMERA



DIAL ASSEMBLY



CONTACT ASSEMBLIES WITH SPEAKER AND MICROPHONE TOP AND BOTTOM

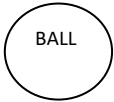

DOUBLE CURSER CONTROLLER, ROLLERBALL MOUSE/MARBEL OR MULTI CONTROLLER JOY STICK

# SIMILING TICKLE

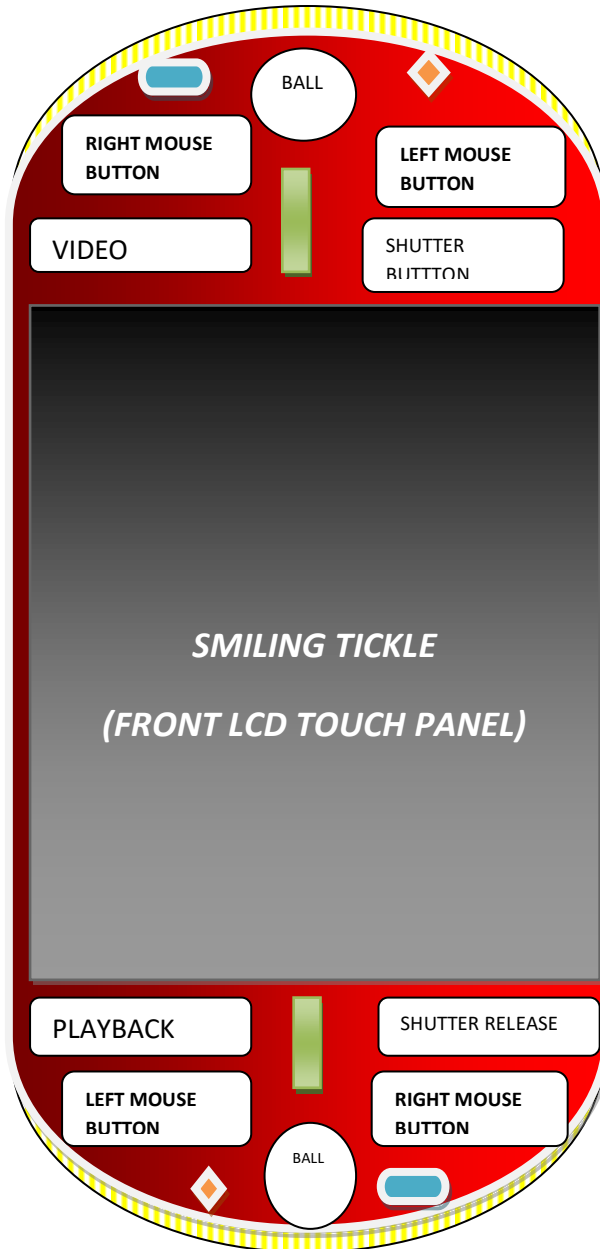

KEY:



FLASH UNIT



CAMERA



DIAL ASSEMBLY



CONTACT ASSEMBLIES WITH SPEAKER AND MICROPHONE TOP AND BOTTOM

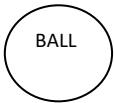

DOUBLE CURSER CONTROLLER, ROLLERBALL MOUSE/MARBEL OR MULTI CONTROLLER JOY STICK

# THE LUSH MAROON

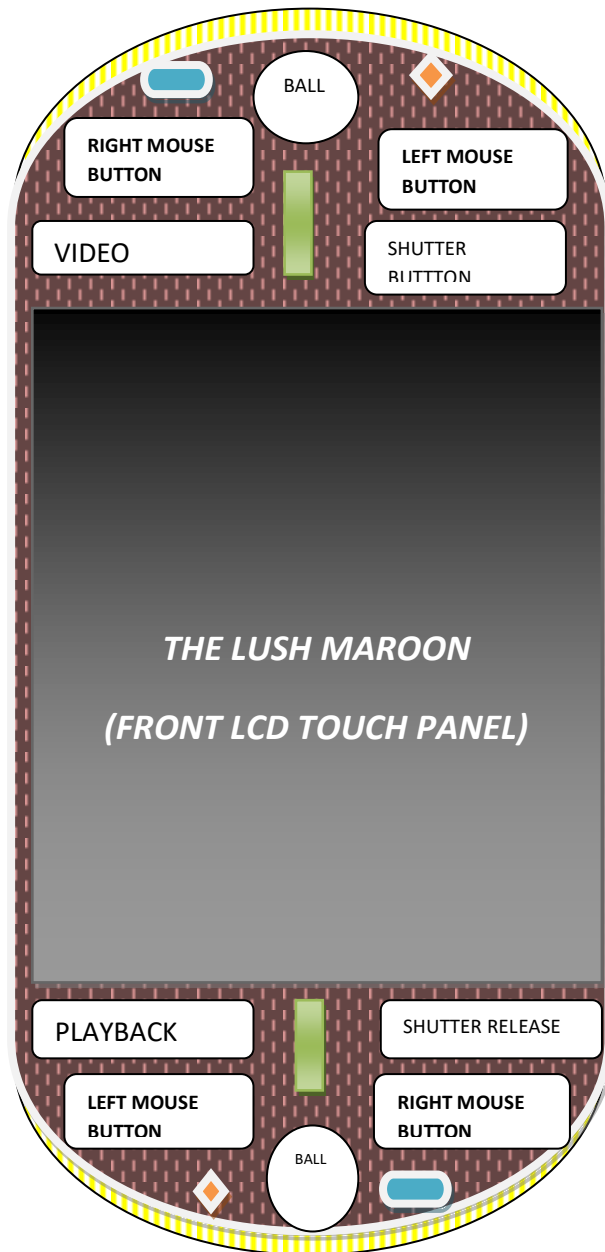

KEY:



FLASH UNIT



CAMERA



DIAL ASSEMBLY



CONTACT ASSEMBLIES WITH SPEAKER AND MICROPHONE TOP AND BOTTOM

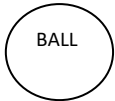

DOUBLE CURSER CONTROLLER, ROLLERBALL MOUSE/MARBEL OR MULTI CONTROLLER JOY STICK

# THE LICK YELLOW

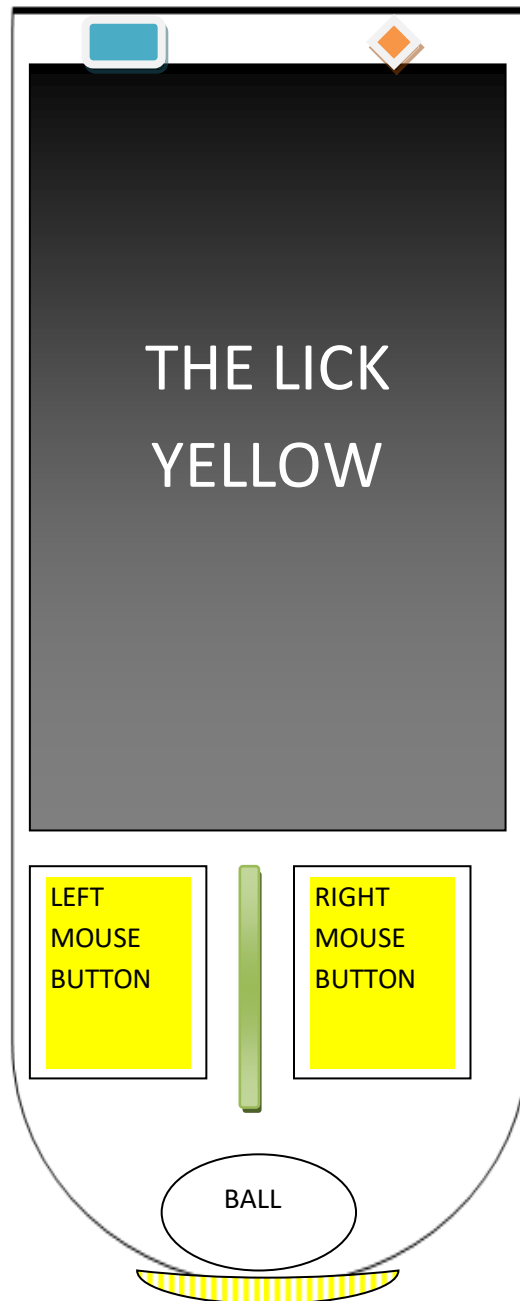

KEY:



FLASH UNIT



CAMERA



DIAL ASSEMBLY



CONTACT ASSEMBLIES WITH SPEAKER AND MICROPHONE TOP AND BOTTOM

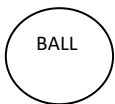

DOUBLE CURSER CONTROLLER, ROLLERBALL MOUSE/MARBEL OR MULTI CONTROLLER JOY STICK

# THE EASY PEEZY

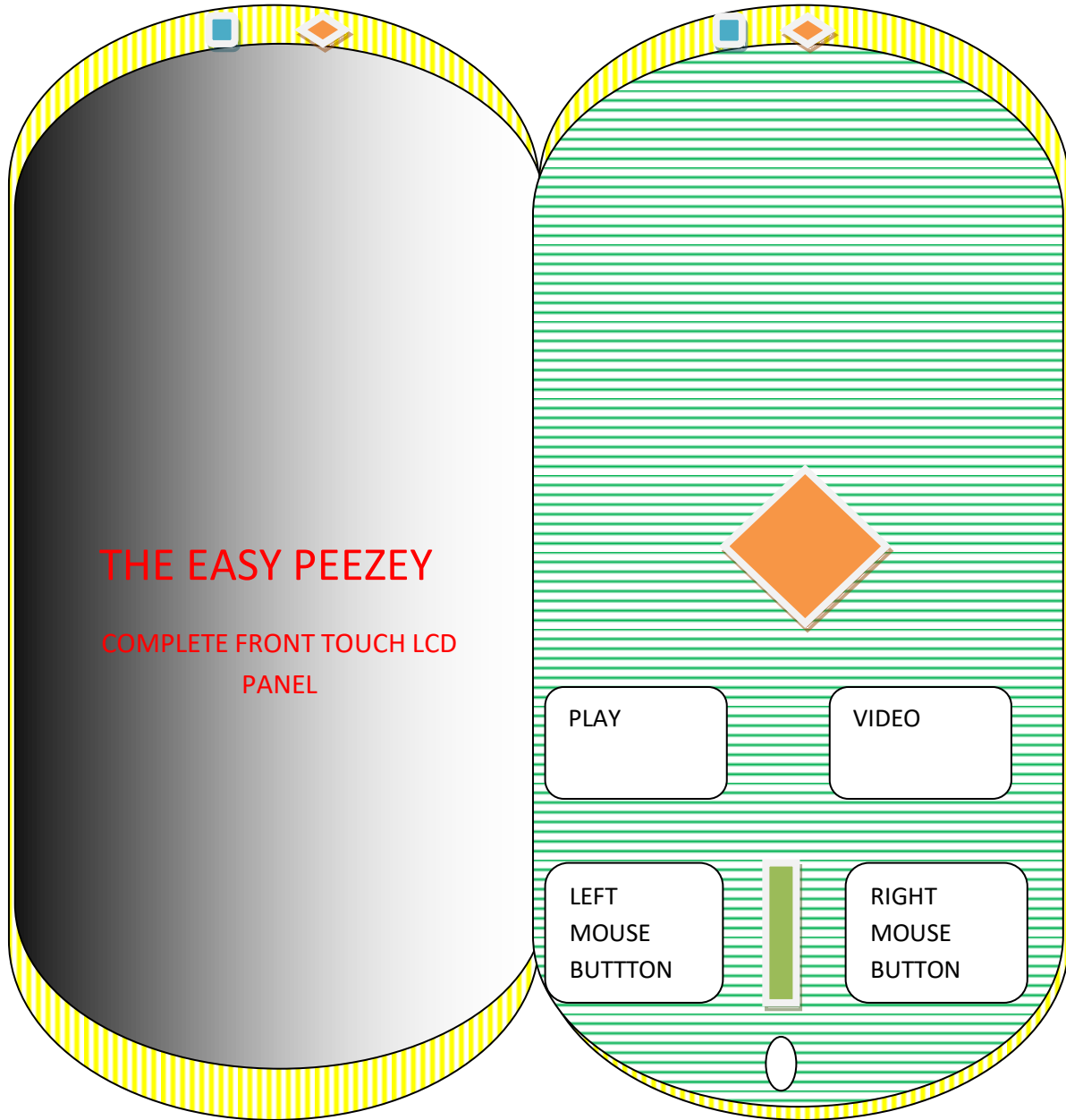

THE EASY PEEZY

COMPLETE FRONT TOUCH LCD  
PANEL

PLAY

VIDEO

LEFT  
MOUSE  
BUTTON

RIGHT  
MOUSE  
BUTTON

KEY:



FLASH UNIT



CAMERA



DIAL ASSEMBLY



CONTACT ASSEMBLIES WITH SPEAKER AND MICROPHONE TOP AND BOTTOM

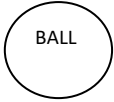

DOUBLE CURSER CONTROLLER, ROLLERBALL MOUSE/MARBEL OR MULTI CONTROLLER JOY STICK

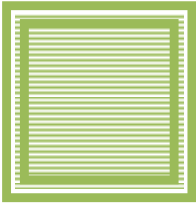

SOLAR BACK

# CONSTANT ECHO

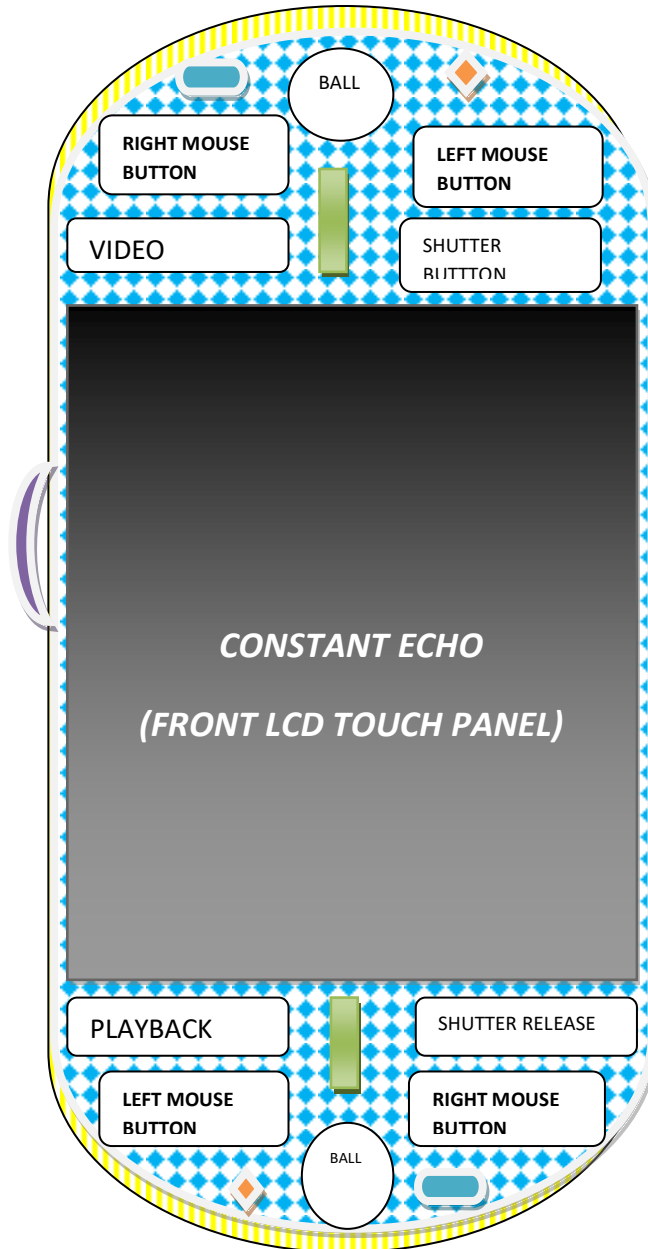

KEY:



FLASH UNIT



CAMERA



DIAL ASSEMBLY



CONTACT ASSEMBLIES WITH SPEAKER AND MICROPHONE TOP AND BOTTOM

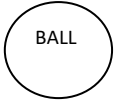

DOUBLE CURSER CONTROLLER, ROLLERBALL MOUSE/MARBEL OR MULTI CONTROLLER JOY STICK



Volume

# SPINNERS EYES/ROLLING SLEEK EYES

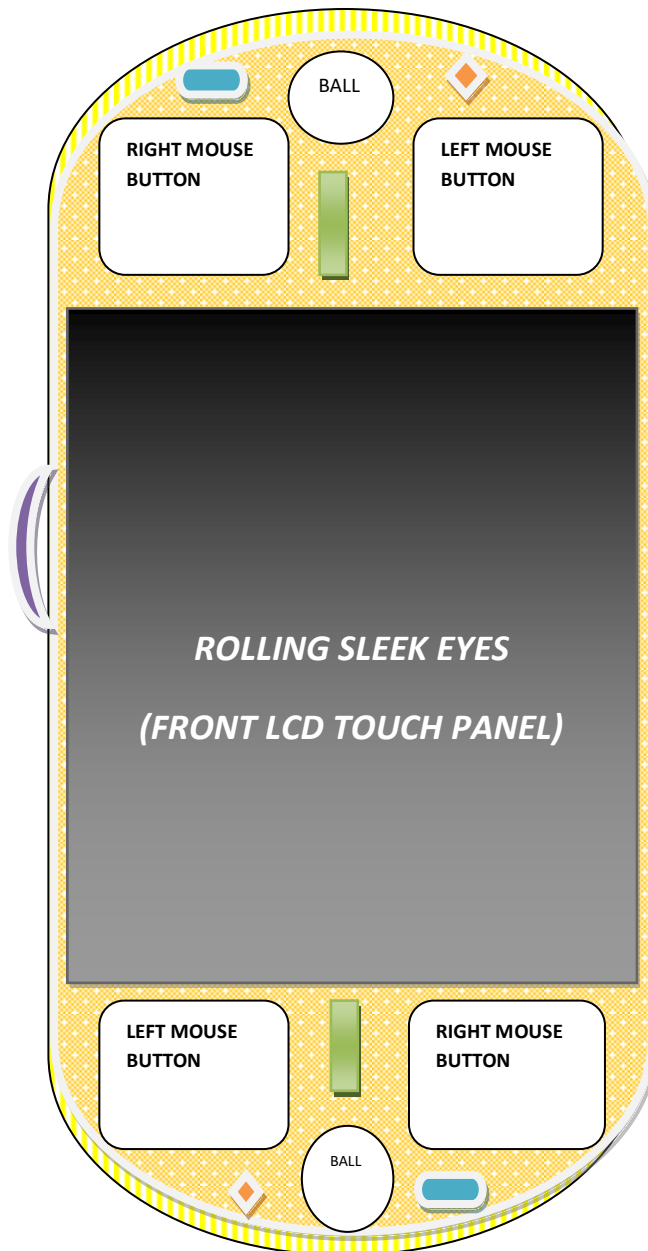

KEY:



FLASH UNIT



CAMERA



DIAL ASSEMBLY



CONTACT ASSEMBLIES WITH SPEAKER AND MICROPHONE TOP AND BOTTOM

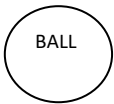

DOUBLE CURSER CONTROLLER, ROLLERBALL MOUSE/MARBEL OR MULTI CONTROLLER JOY STICK



Volume

# KISSY RIGHT NOW

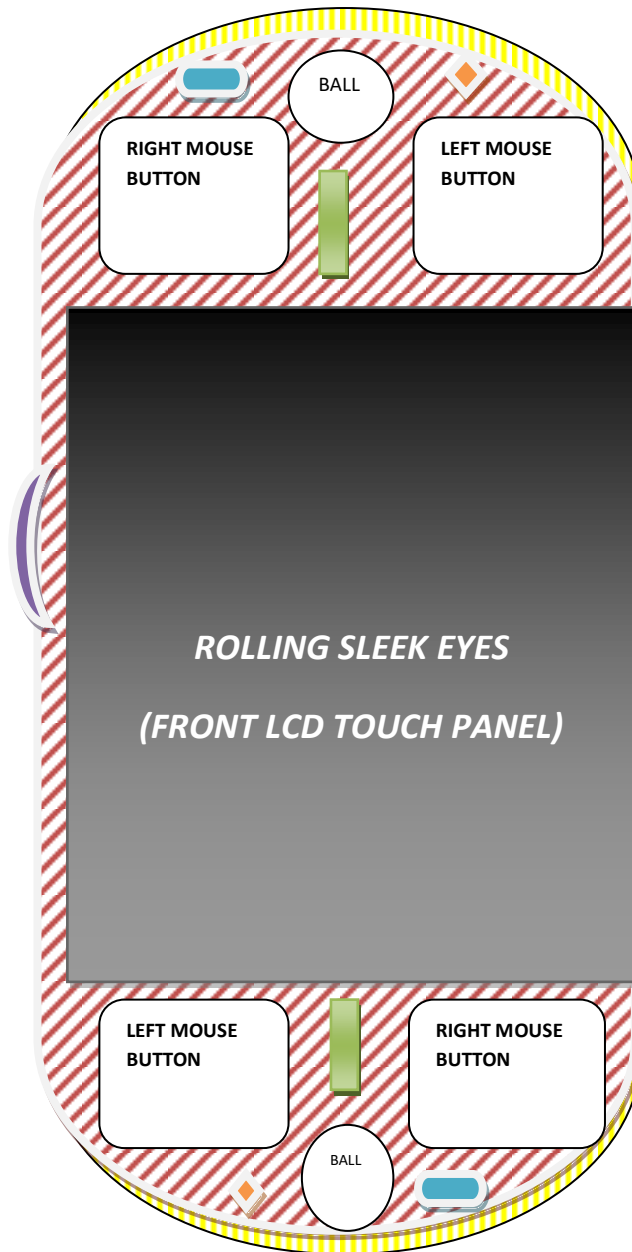

KEY:



FLASH UNIT



CAMERA



DIAL ASSEMBLY



CONTACT ASSEMBLIES WITH SPEAKER AND MICROPHONE TOP AND BOTTOM

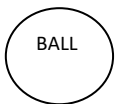

DOUBLE CURSER CONTROLLER, ROLLERBALL MOUSE/MARBEL OR MULTI CONTROLLER JOY STICK



Volume

# CHAT AND IMPRESS COMPUTER PAD

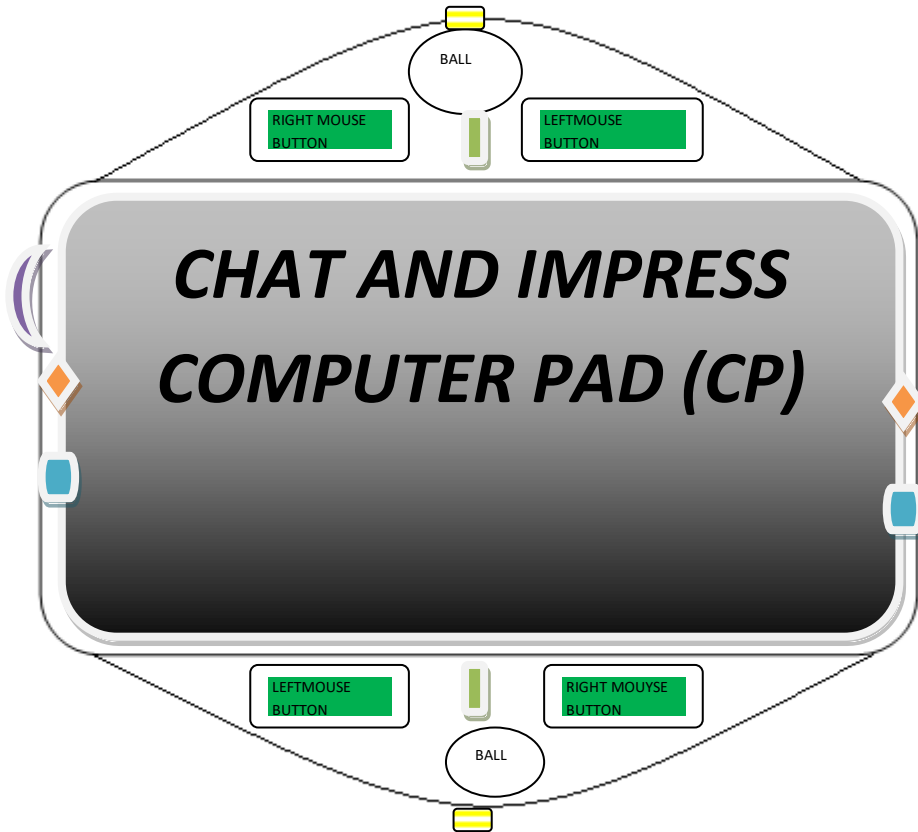

KEY:



FLASH UNIT



CAMERA



DIAL ASSEMBLY



CONTACT ASSEMBLIES WITH SPEAKER AND MICROPHONE TOP AND BOTTOM

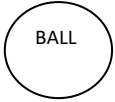

DOUBLE CURSER CONTROLLER, ROLLERBALL MOUSE/MARBEL OR MULTI CONTROLLER JOY STICK



Volume

# SLICK CITY COMPUTER PAD

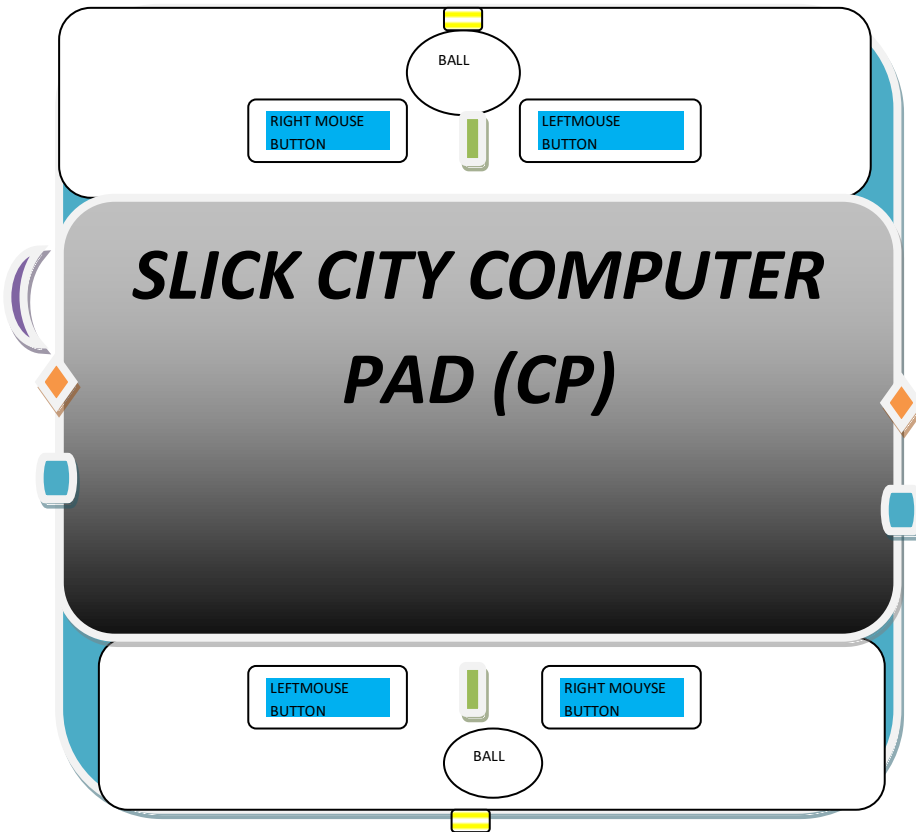

KEY:



FLASH UNIT



CAMERA



DIAL ASSEMBLY



CONTACT ASSEMBLIES WITH SPEAKER AND MICROPHONE TOP AND BOTTOM

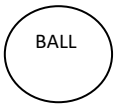

DOUBLE CURSER CONTROLLER, ROLLERBALL MOUSE/MARBEL OR MULTI CONTROLLER JOY STICK



Volume

# NICE AND SENSUAL COMPUTER PAD

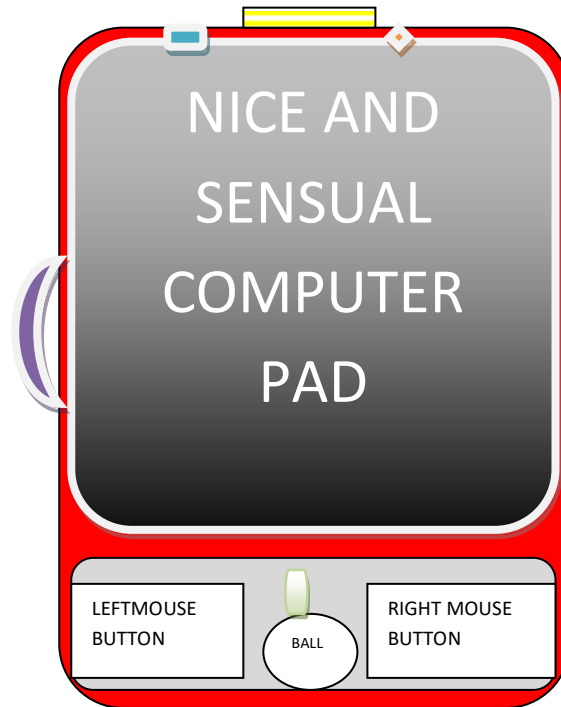

KEY:



FLASH UNIT



CAMERA



DIAL ASSEMBLY



CONTACT ASSEMBLIES WITH SPEAKER AND MICROPHONE TOP AND BOTTOM

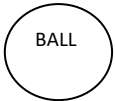

DOUBLE CURSER CONTROLLER, ROLLERBALL MOUSE/MARBEL OR MULTI CONTROLLER JOY STICK



Volume

# DONT TEST ME



KEY:



FLASH UNIT



CAMERA



DIAL ASSEMBLY



CONTACT ASSEMBLIES WITH SPEAKER AND MICROPHONE TOP AND BOTTOM

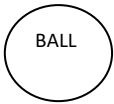

DOUBLE CURSER CONTROLLER, ROLLERBALL MOUSE/MARBEL OR MULTI CONTROLLER JOY STICK



Volume

# LIP TEEZER

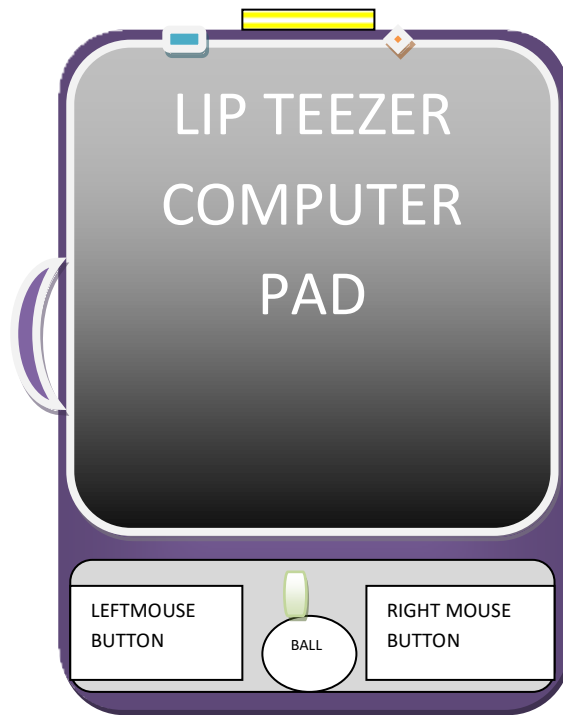

KEY:



FLASH UNIT



CAMERA



DIAL ASSEMBLY



CONTACT ASSEMBLIES WITH SPEAKER AND MICROPHONE TOP AND BOTTOM

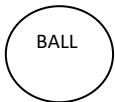

DOUBLE CURSER CONTROLLER, ROLLERBALL MOUSE/MARBEL OR MULTI CONTROLLER JOY STICK



Volume

## CLASS & STYLE

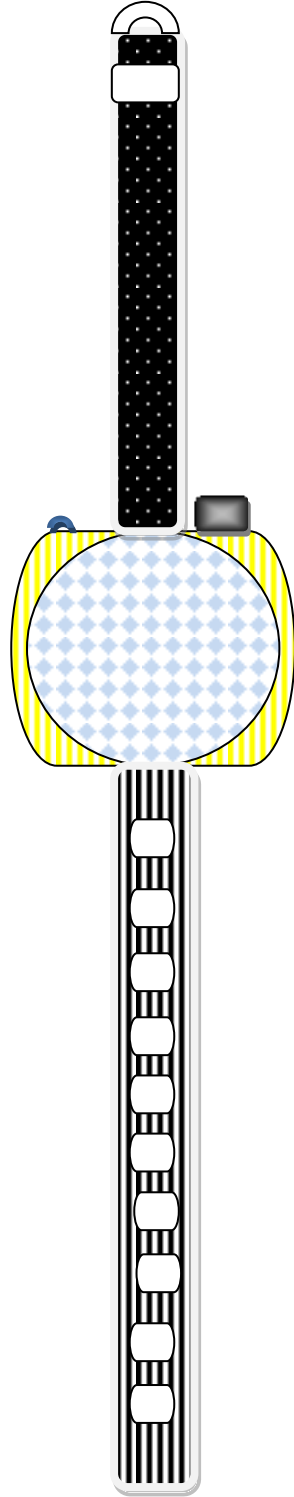

# LINE GAMES

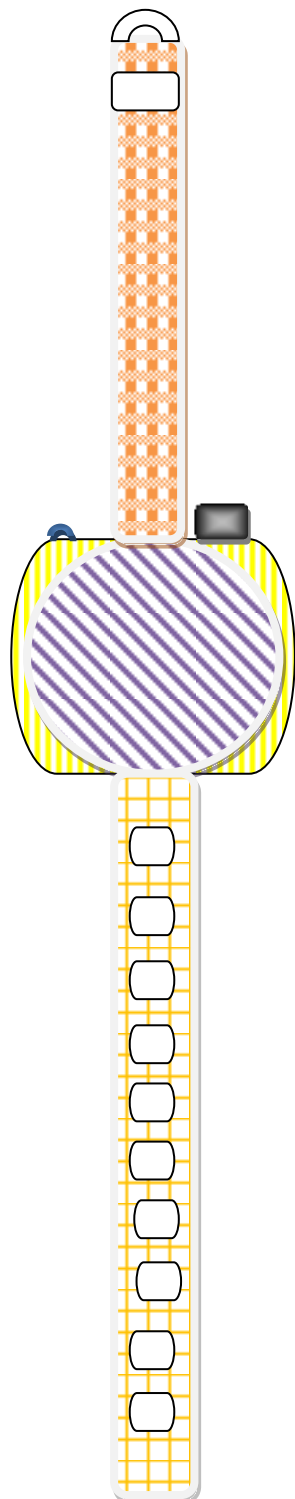

# BIG CHEEKEY

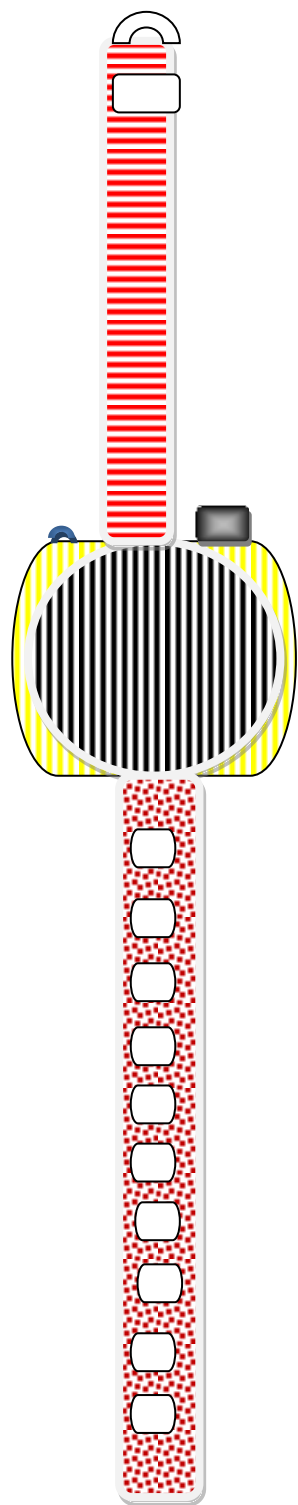

# DOUBLE TROUBLE

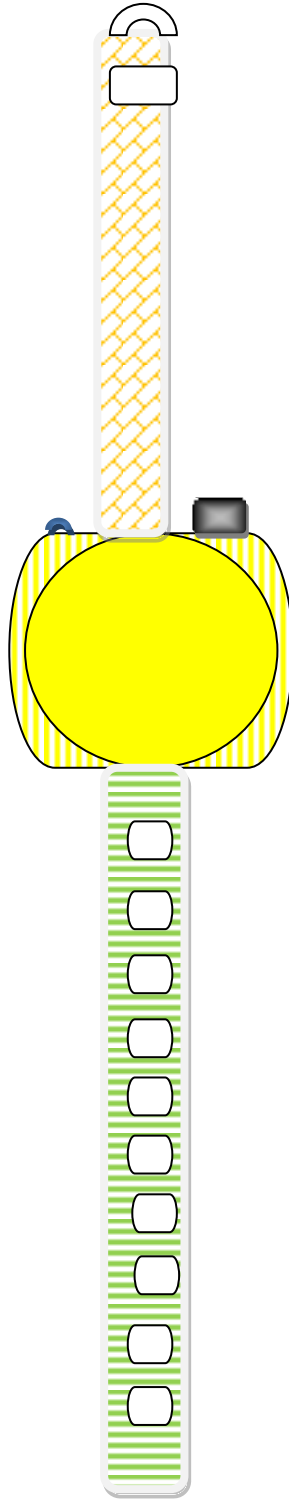

# DAY TIME SUN SHINE & SUN SET

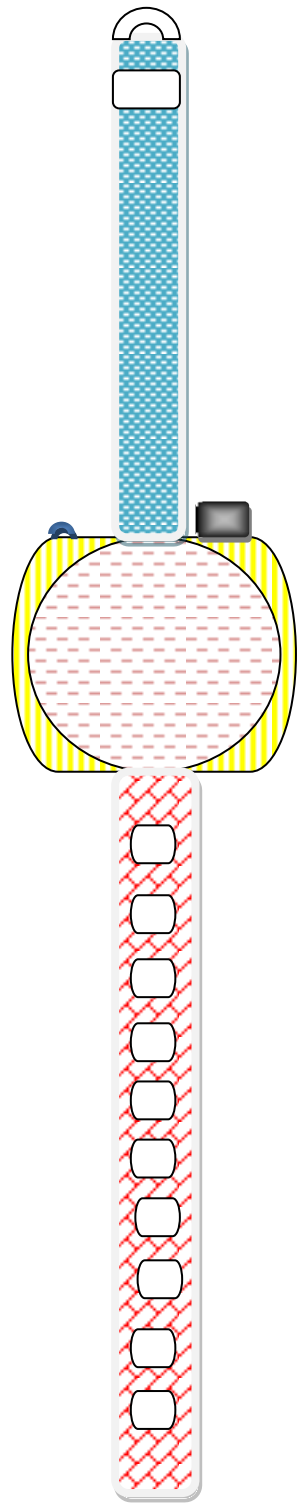

LOVE RURAL

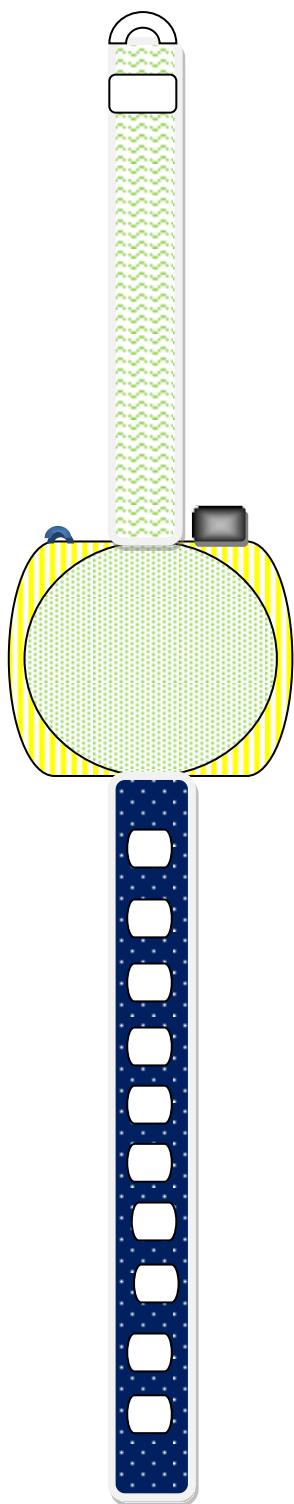

SWITCHED ON 24/7

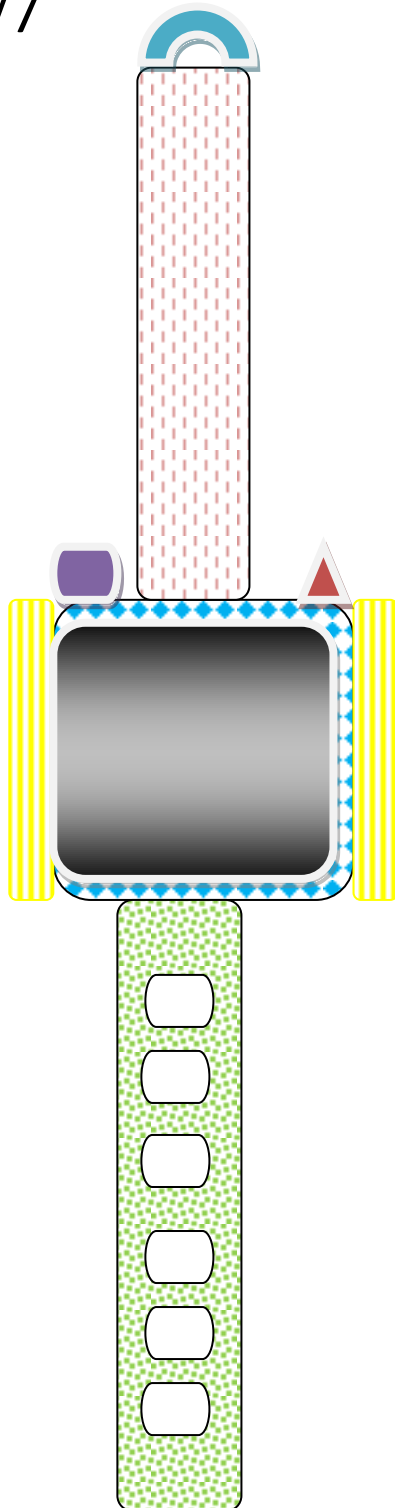

TO MUCH LOVE FOR ME

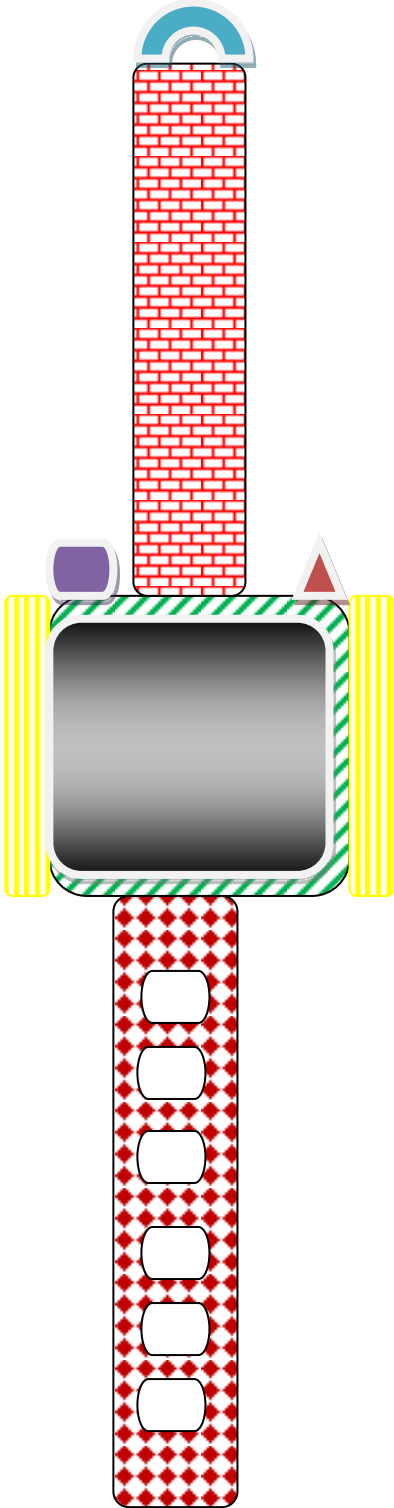

# TIME TELLER

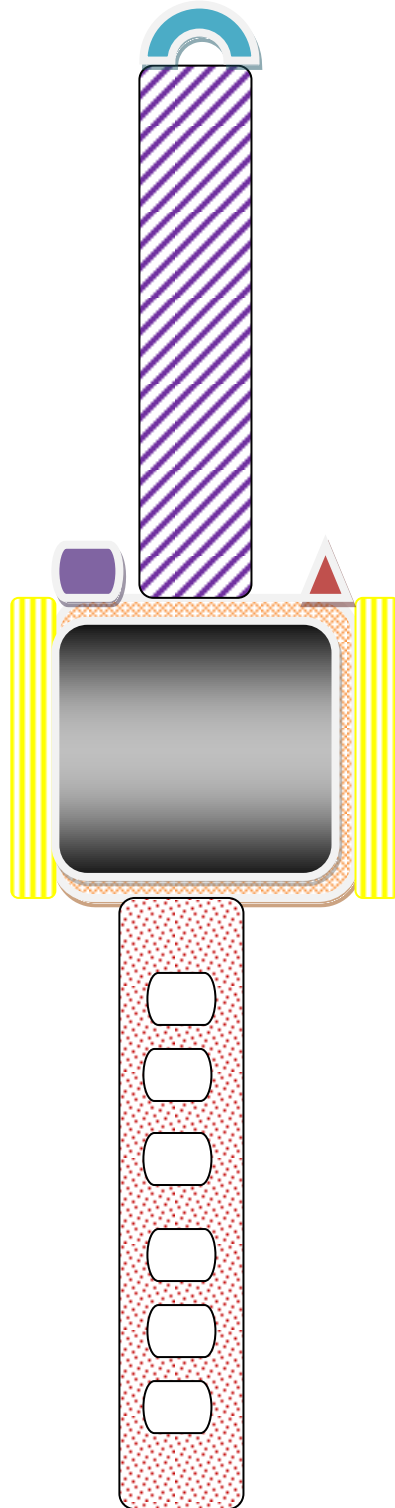

# NATURAL THILLER

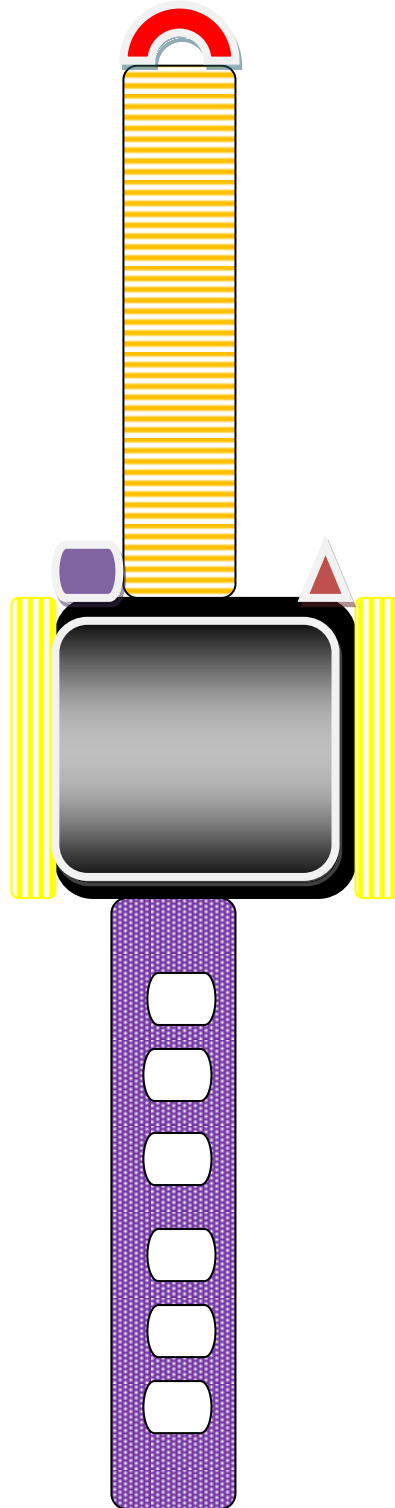

# BEUTIFULL VIEW PAY BY KEY SETS

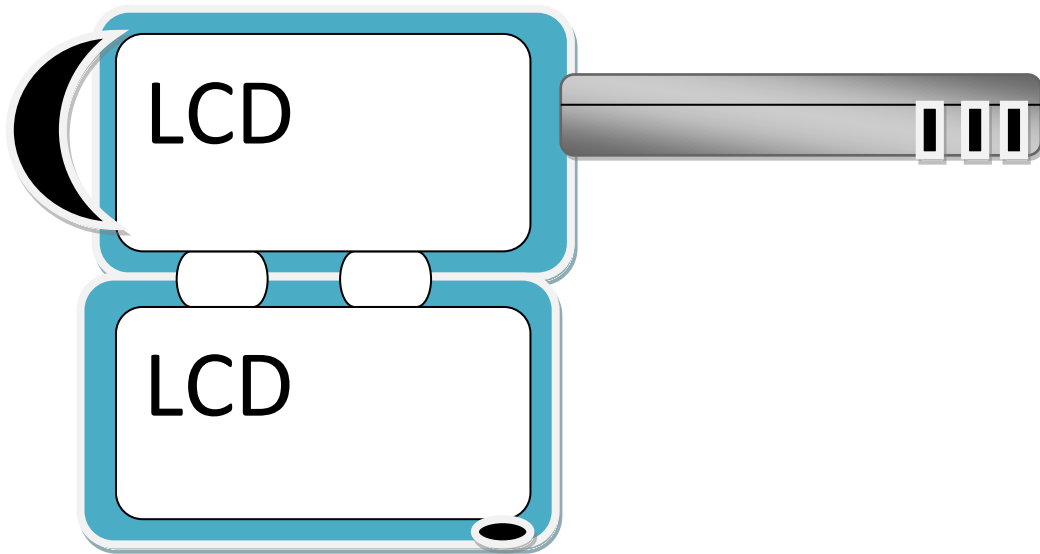

ALL OVER NOW PAY BY KEY

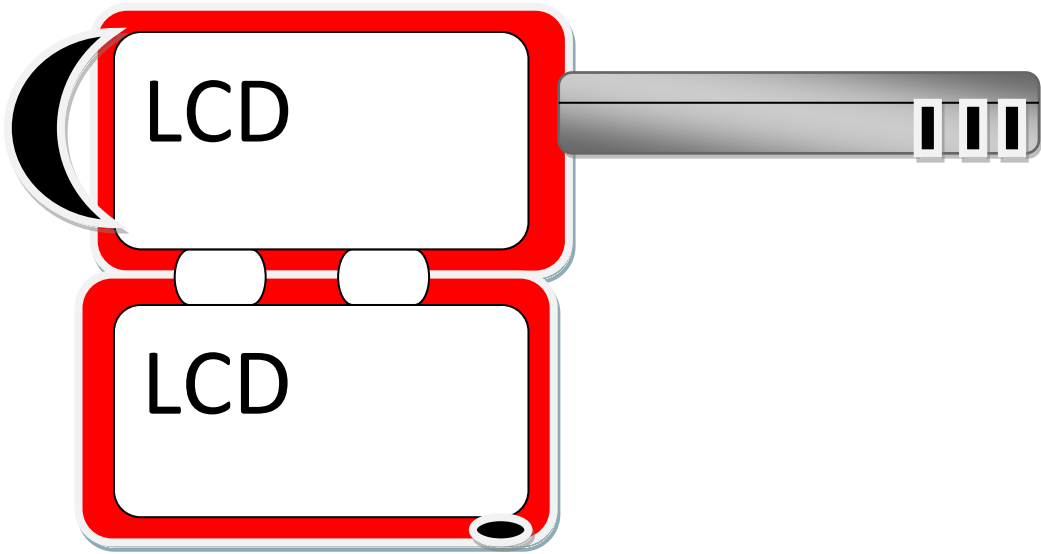

# BELTED UP PAY BY KEY

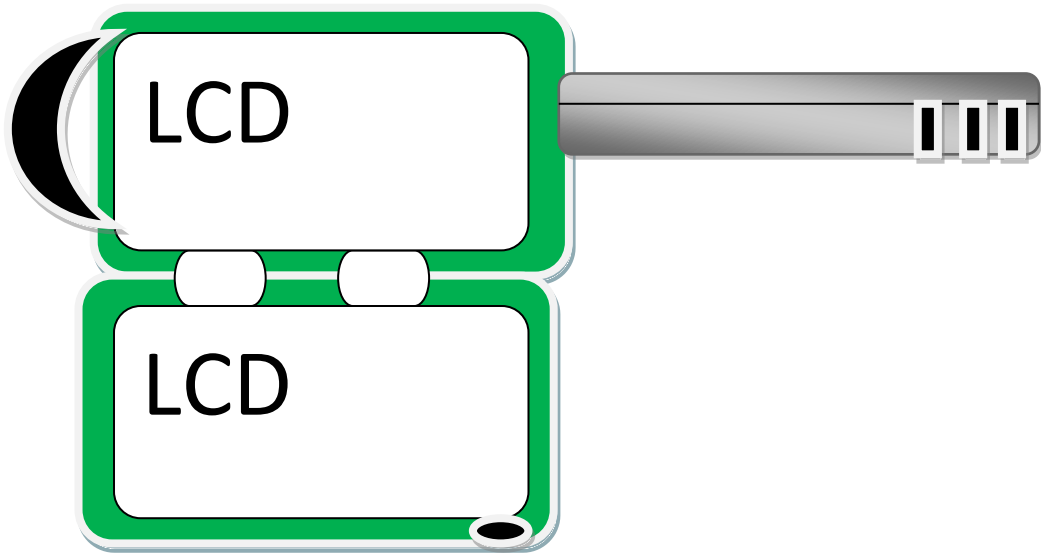

# STRONG BOLD PAY BY KEY

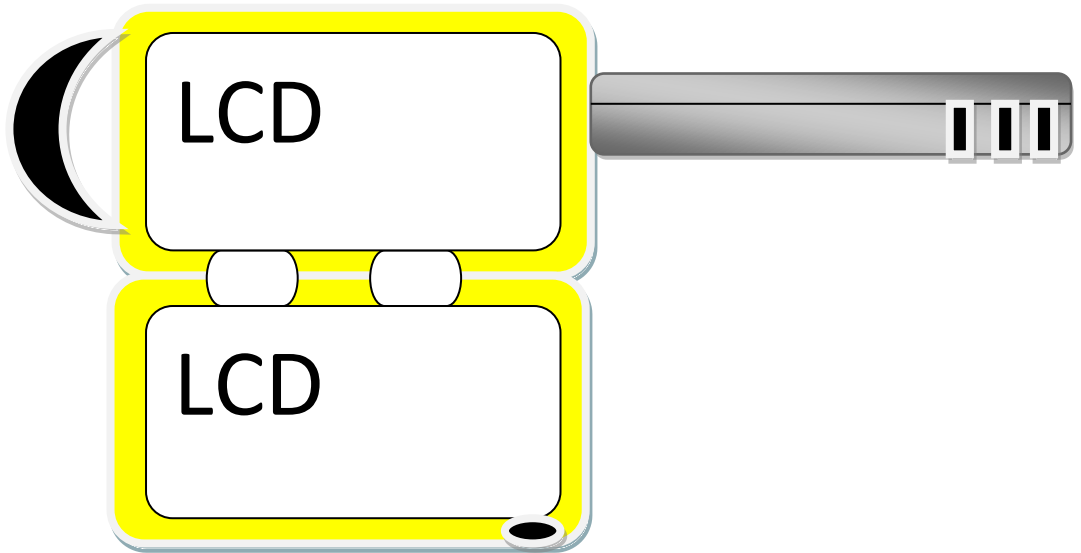

# SUSTAINED ENDURE PAY BY KEY

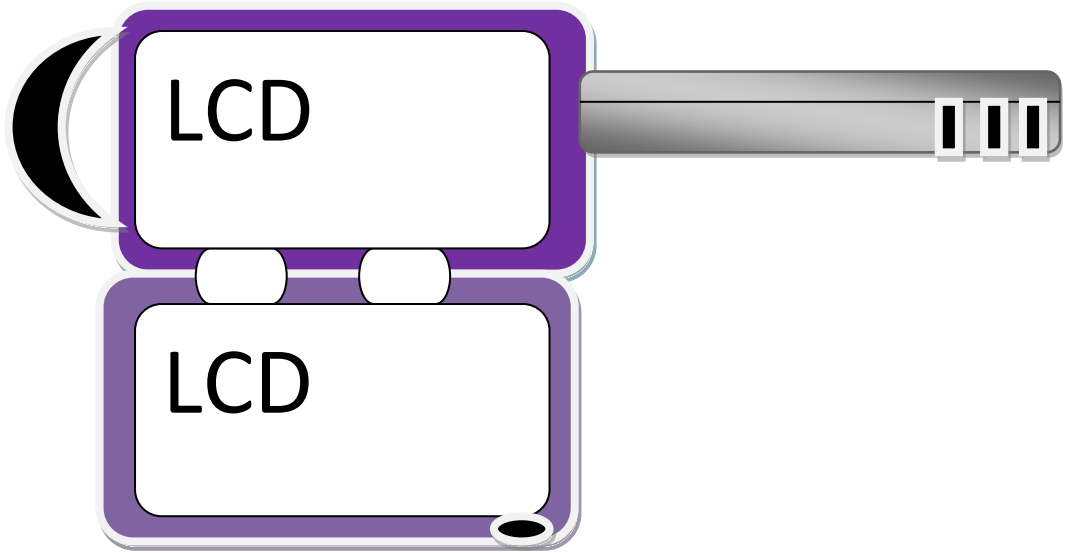

ENJOY ENJOY

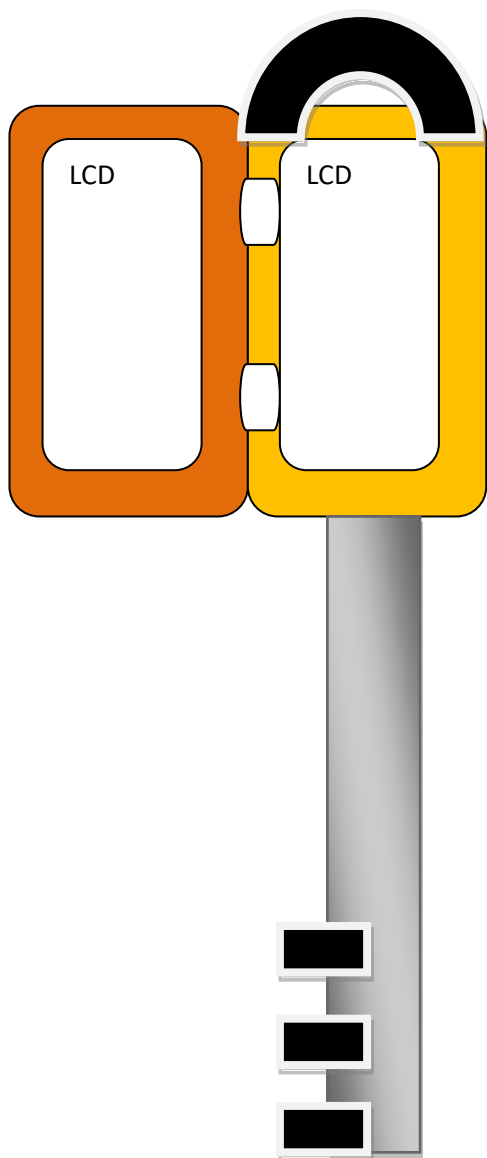

# FOEVER CLEAVER

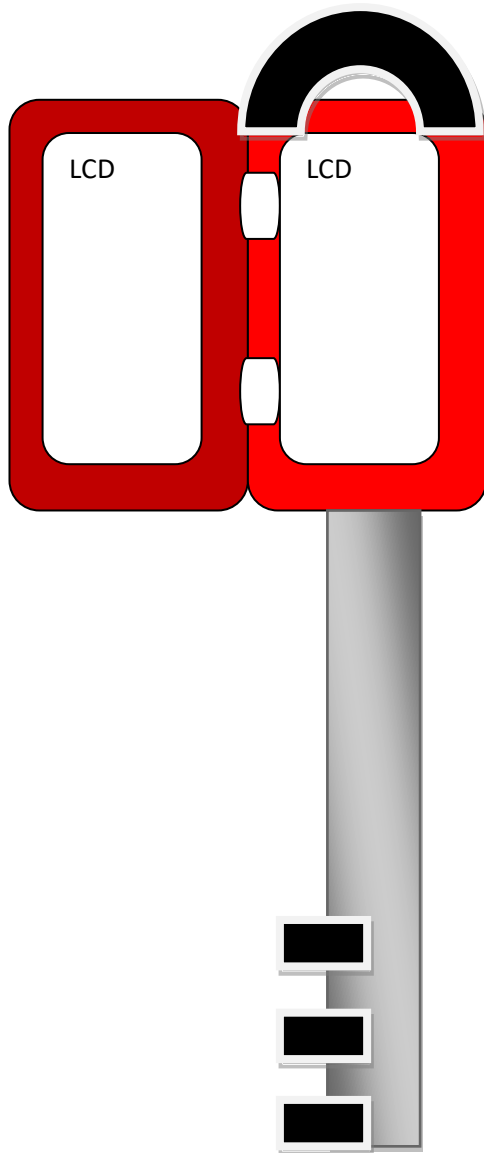

CAN BREATHE

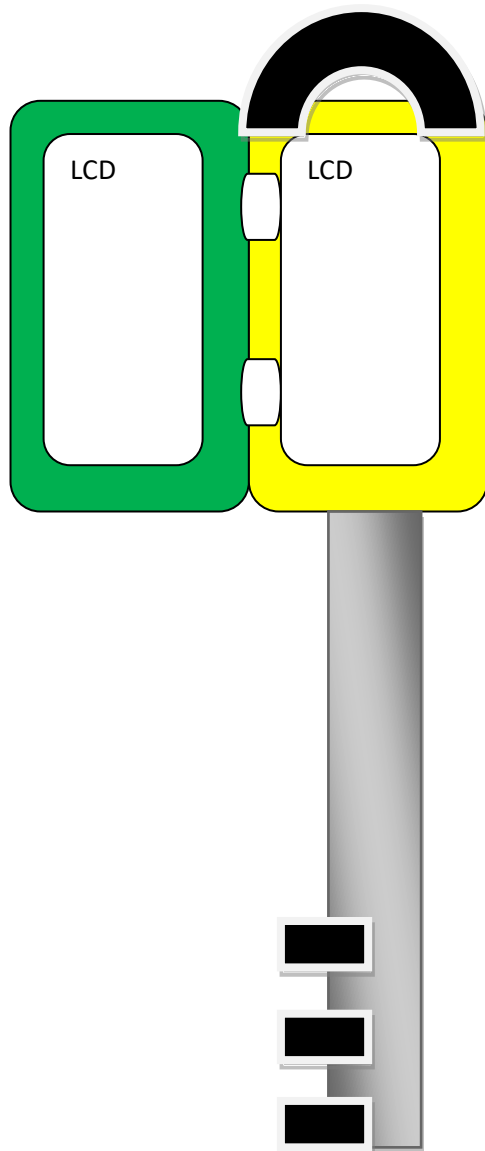

# SOFT SILK CITY

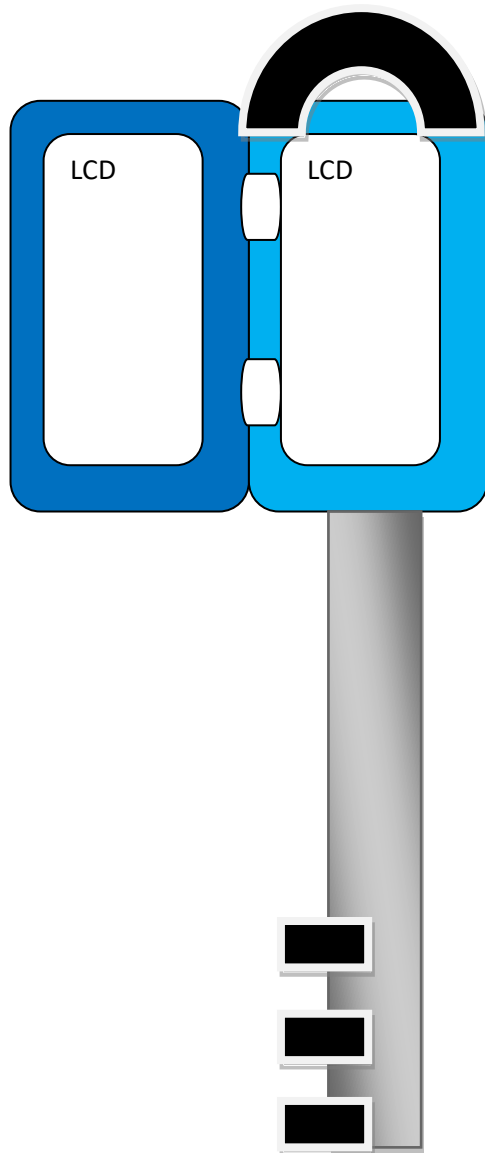

# RELAX AND GREEN

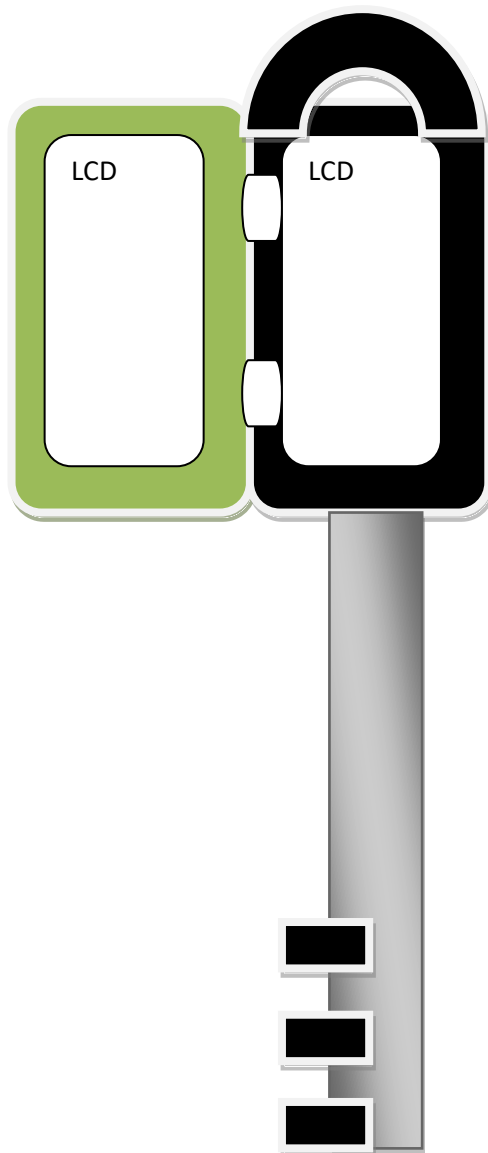

# SKULL RIPPER

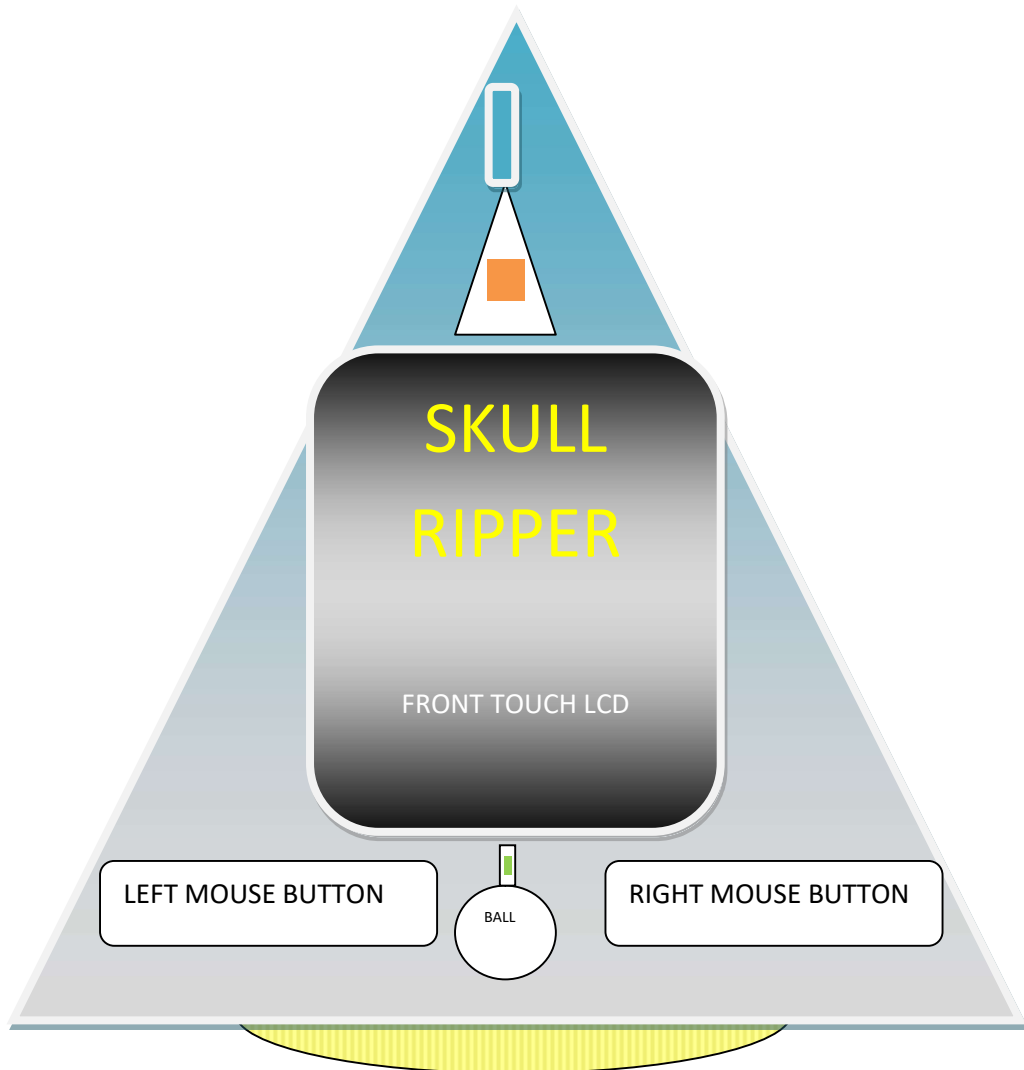

# BRIDGE BLOWER

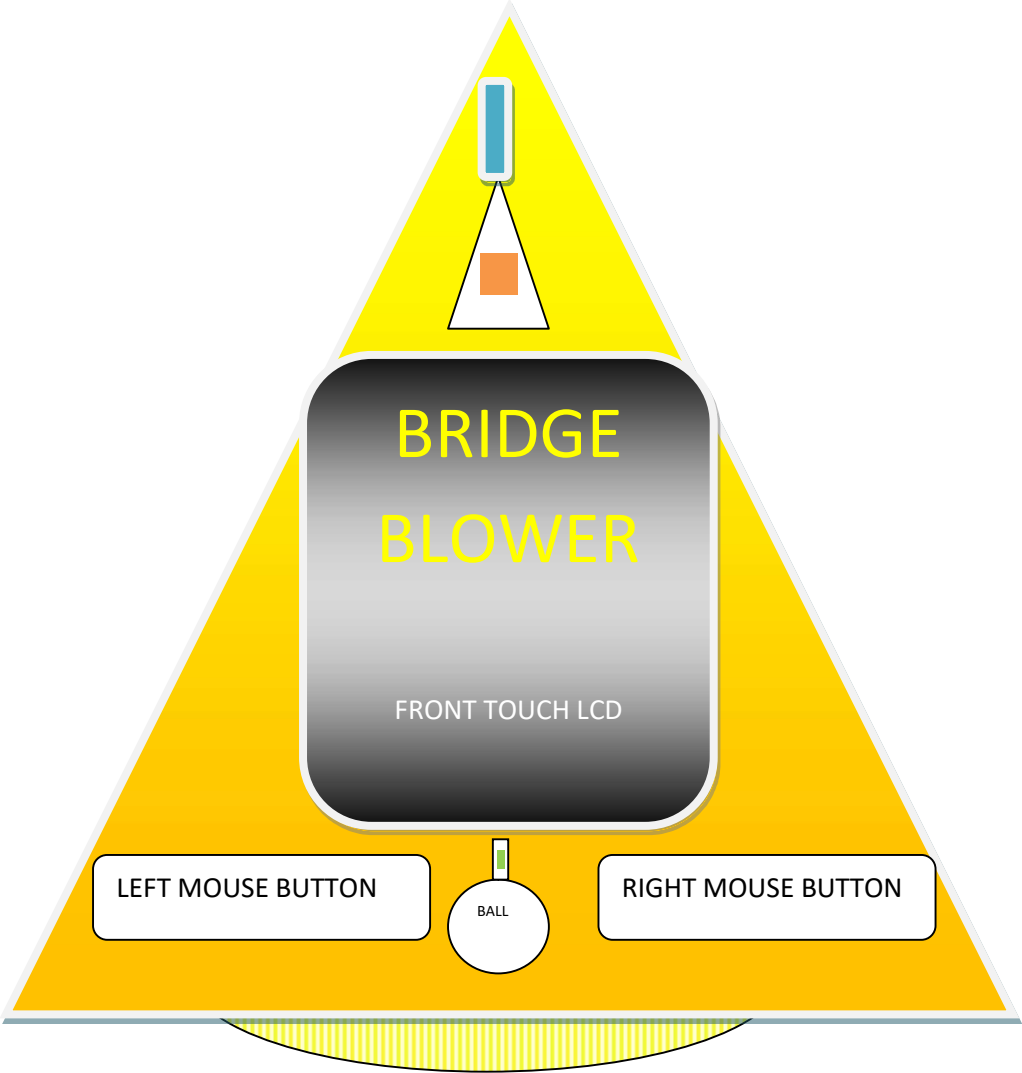

# PURPLE TWILIGHT

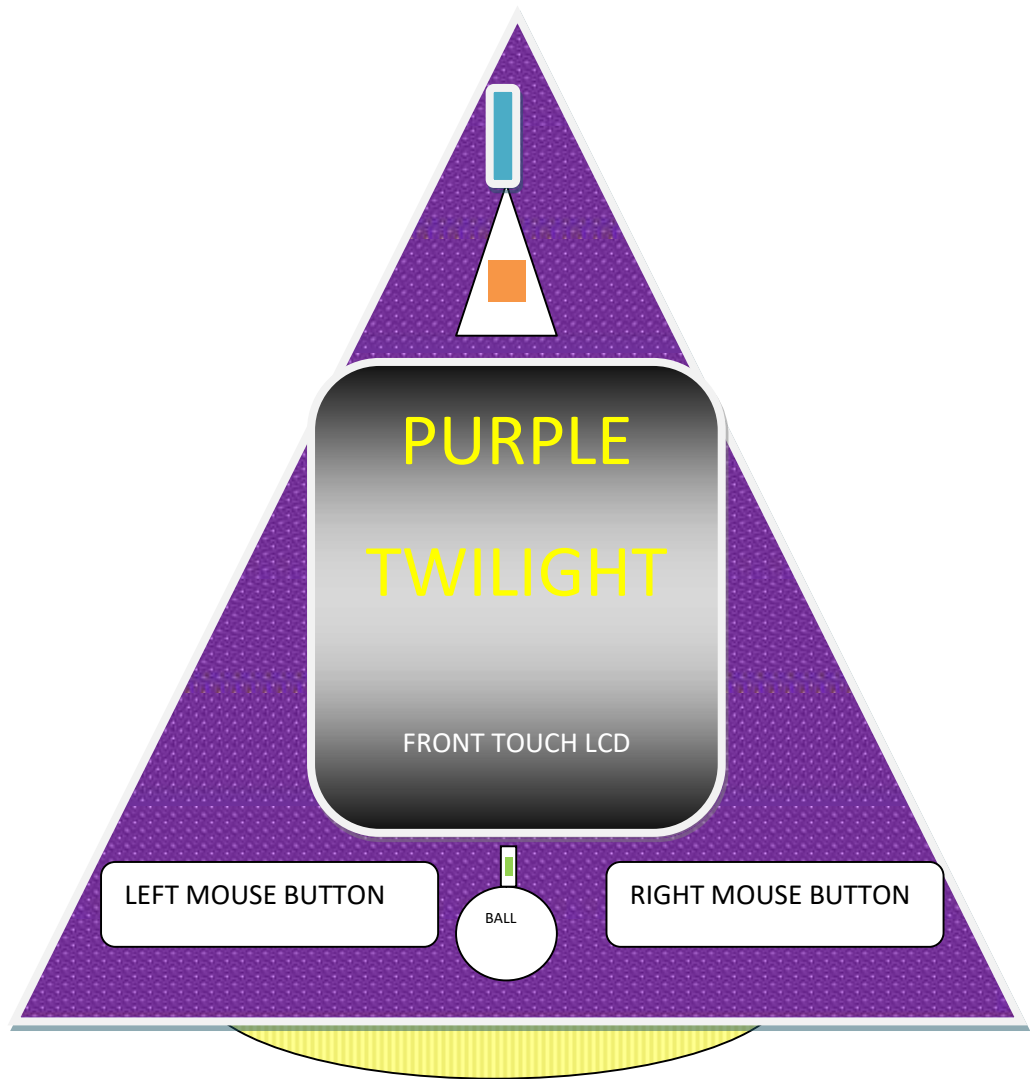

# OPEN FIRE

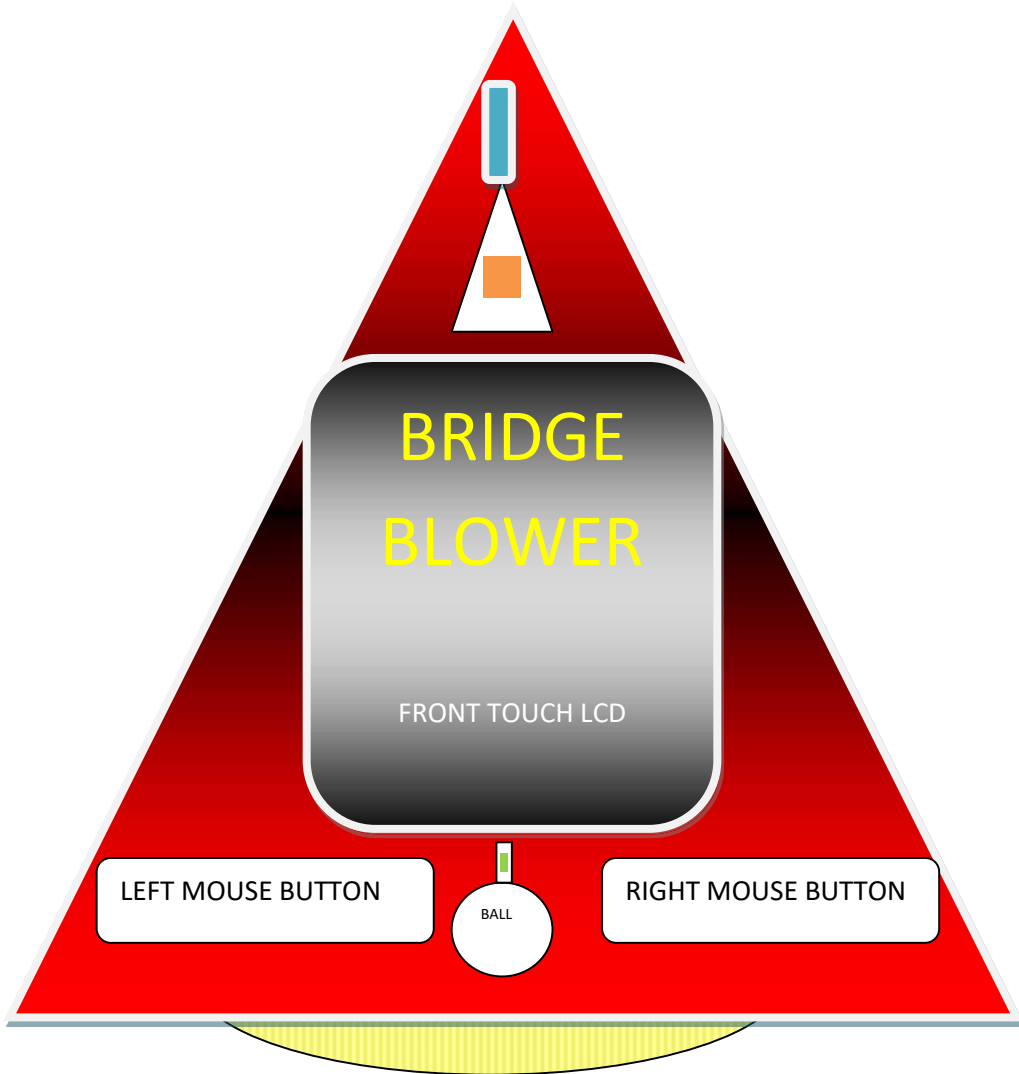

# WATERFALL VALLEY

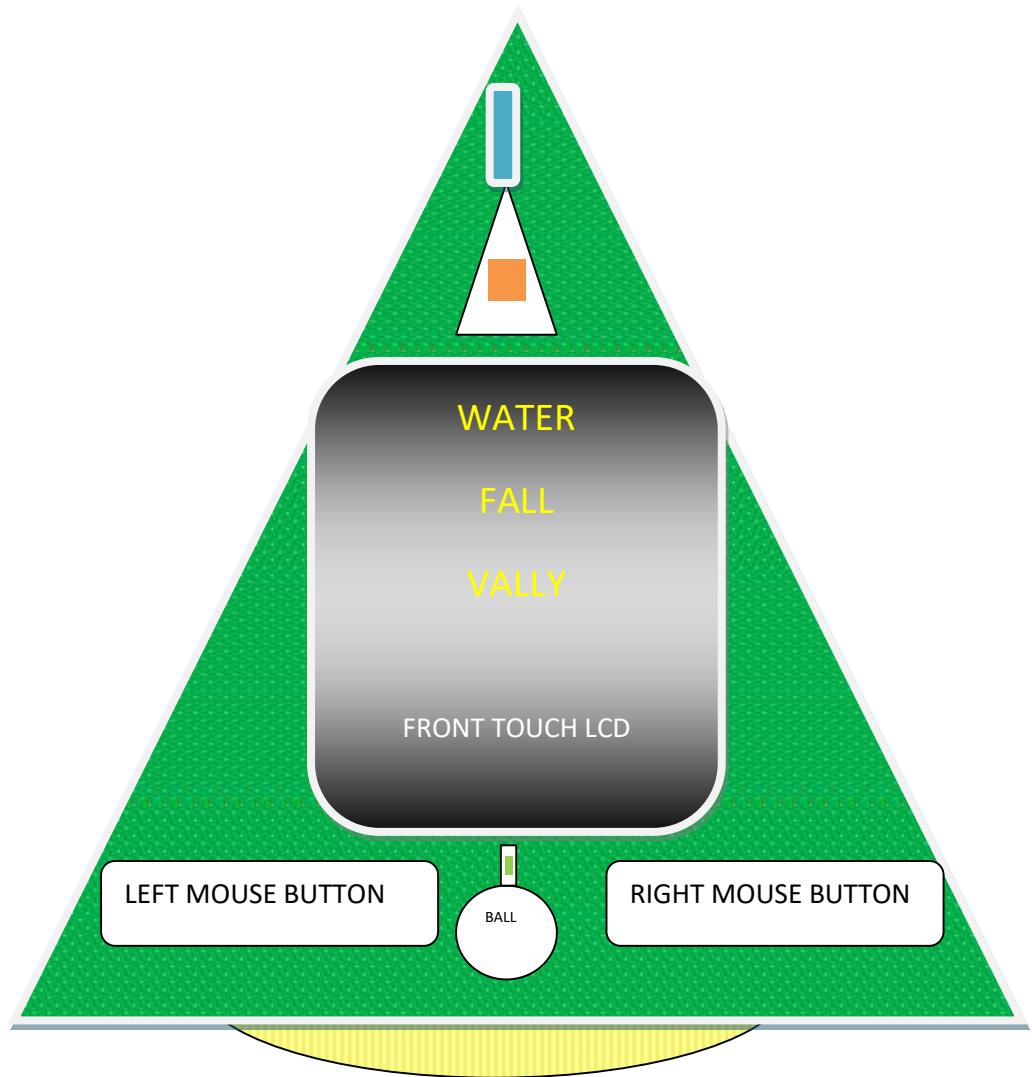

SPREAD WIDE (YOU TUBE MUSIC PLAYER AUDIO)

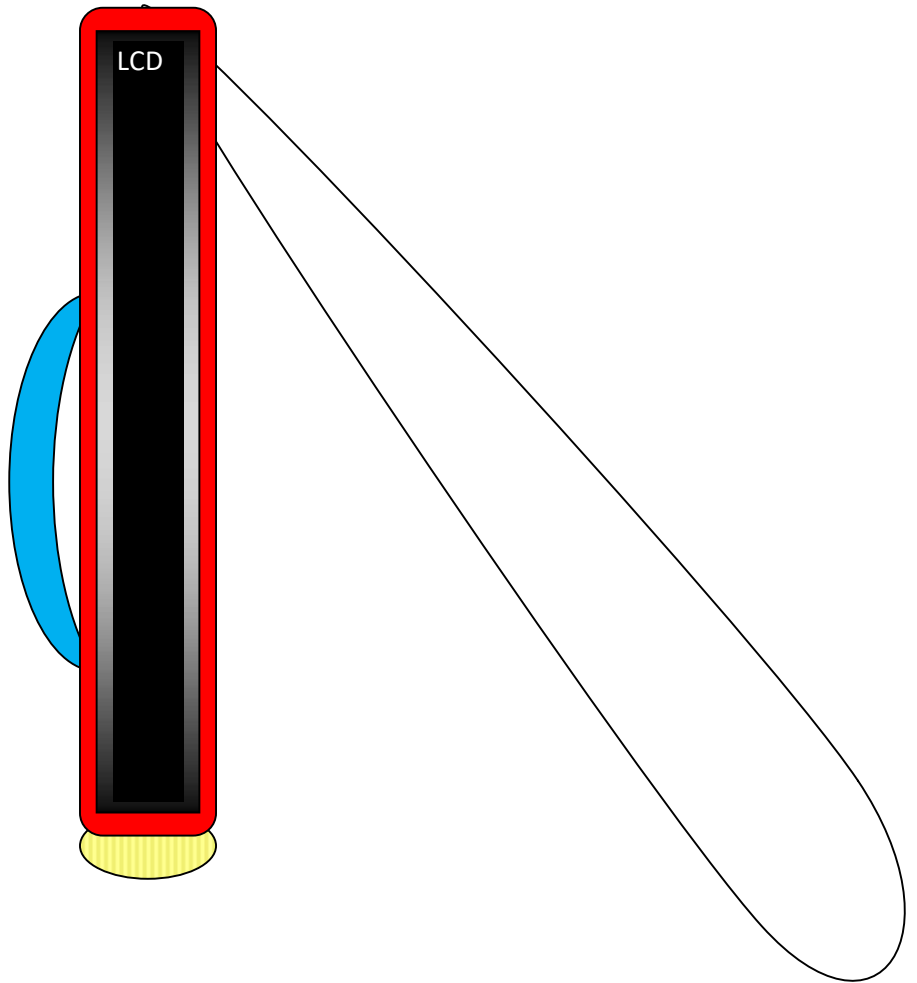

# FAST UP & DOWN (YOU TUBE MUSIC PLAYER)

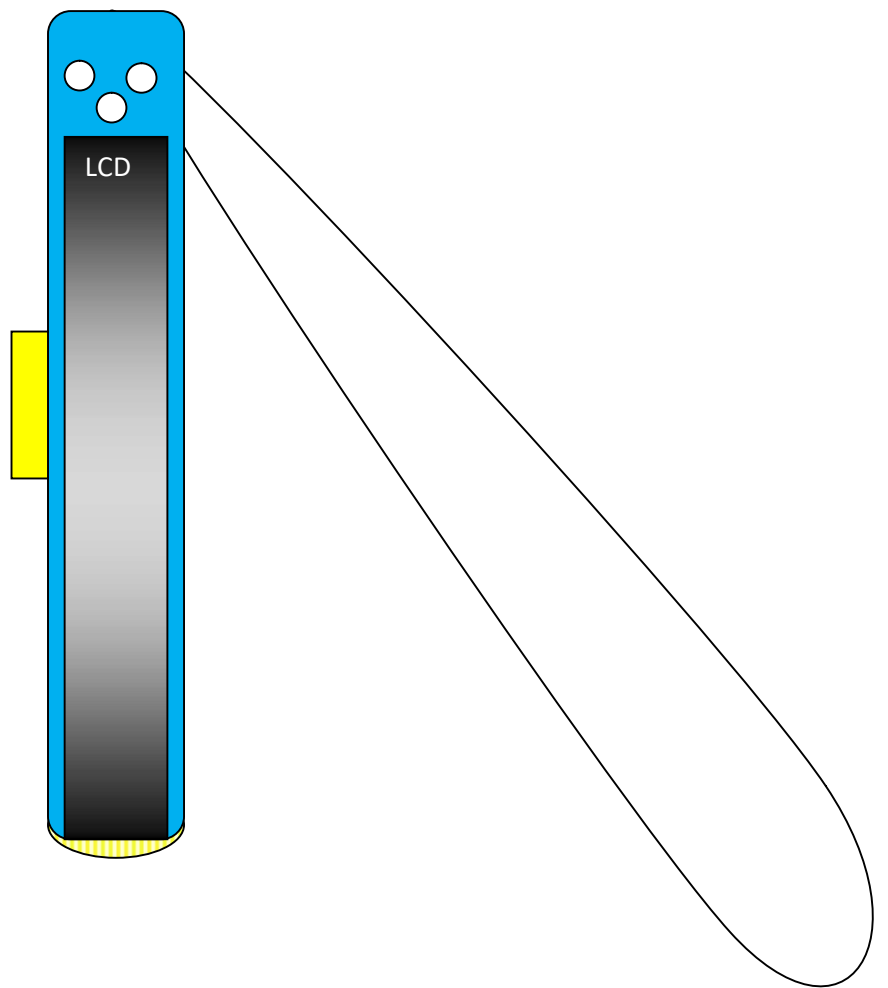

# QUICK CLIMAX (YOU TUBE AUDIO PLAYER)

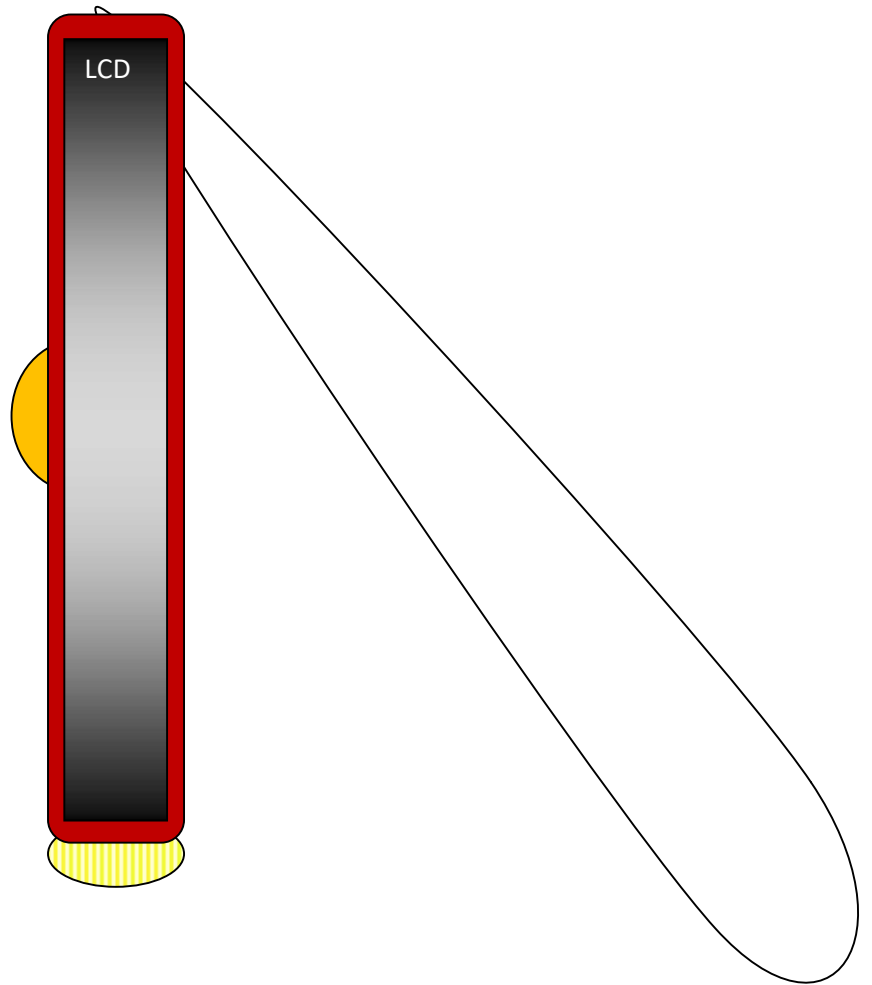

# UNTOUCHABLE NIGHT

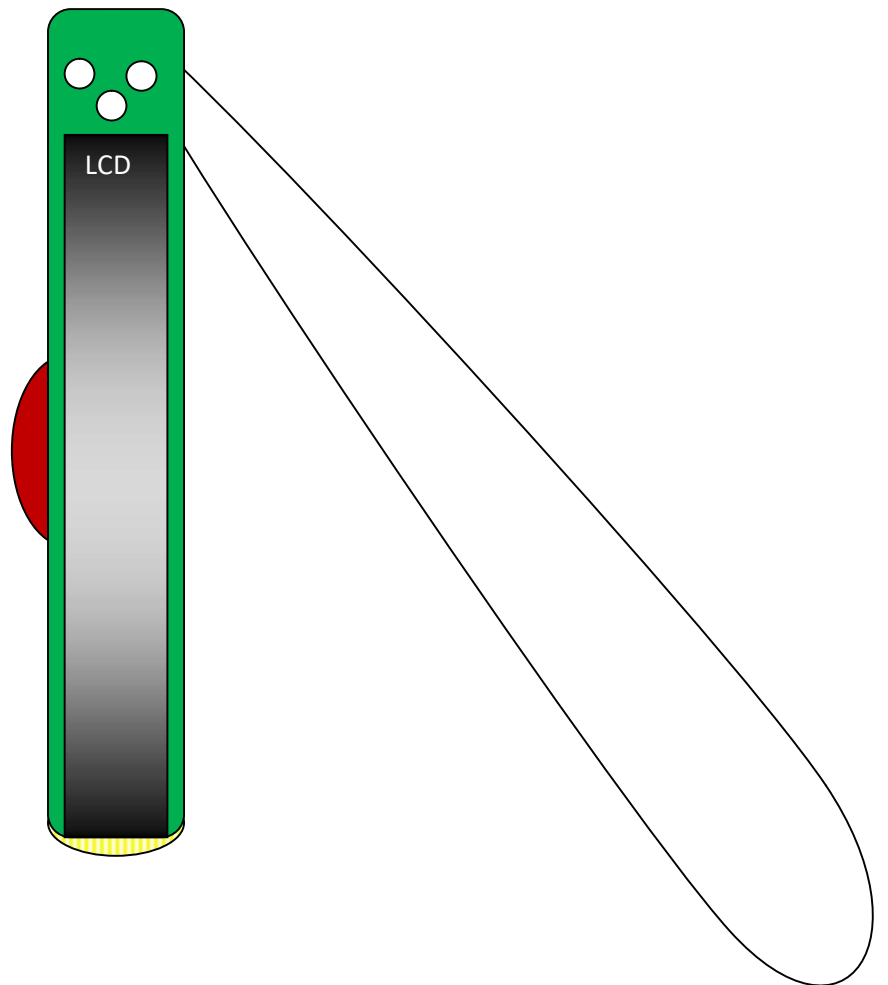

# COWS WORLD

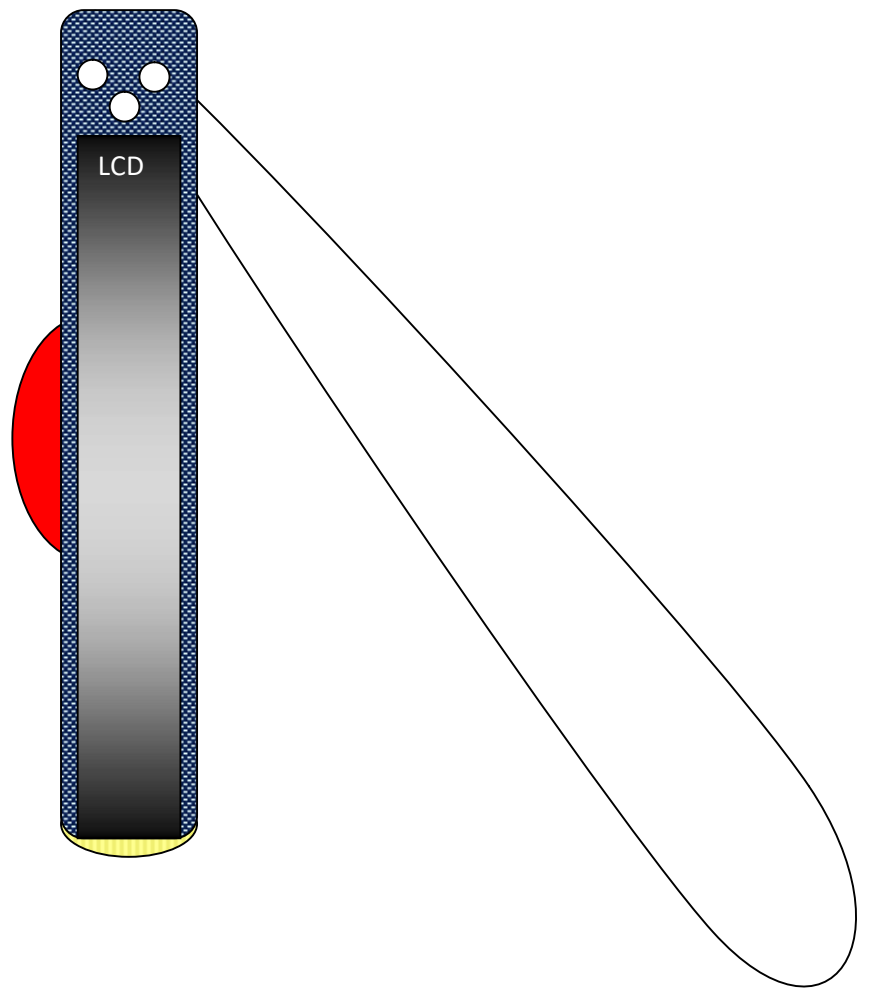

# LOVE LISTENING



# VALANTINE TOUCH





# Patent Cooperation Treaty (PCT) fees

**We will only process PCT forms with this completed fee sheet. Use one fee sheet per application or payment.**

Your own reference (optional) 18 characters  
maximum

2510010

## Section 1

**Contact details** (in case we have a query) Name

Email

sushil@eurohitech.com

Phone

00447915382908

## Section 2

### Fees

**Tick one**

I am paying the fees with the application – supply total number of sheets

Total number of sheets: **4** (from Box IX on PCT/RO/101) Next, complete sections 3 and 4, then go to section 5

I am paying the fees for an earlier application – supply PCT number PCT

number: PCT/GB20

Next, complete sections 3 and 4, then go to section 5

I will be paying the application fees within one month – supply total number of sheets

Total number of sheets:  (from Box IX on PCT/RO/101)

Next, go to section 5

## Section 3

### Fee details

To check the current fees for this form - search on GOV.UK for '[PCT fees](#)'

Transmittal fee	£75.00
Search fee	£1548.00
International filing fee, including any reduction, late fee or fee for excess sheets	£1010.00
Fee for priority document(s)	£0.00
Fee for restoration of the right of priority	£0.00
<b>Total</b>	<b>£2633.00</b>

## Section 4

### Payment details

Tick One

**Deduct from IPO deposit account**

IPO deposit account number

**Cheque** – make payable to 'Intellectual Property Office' and enclose with forms

**Bank transfer**

Reference – use your IPO deposit account number if you have one or an application number, or your name, if you don't

**Use the following bank account details:**

Sortcode	20-18-23
Account number	80531766
Account name	Intellectual Property Office
SWIFT code	BARCGB22
IBAN number	GB92BARC20182380531766

## Section 5

### Send to us

**E-mail:** [forms@ipo.gov.uk](mailto:forms@ipo.gov.uk)

**Post:** Print this fee sheet and together with the PCT paperwork, send to: Intellectual Property Office, Concept House, Cardiff Road, Newport, South Wales, NP10 8QQ, United Kingdom

# PATENT COOPERATION TREATY

From the RECEIVING OFFICE

# PCT

## NOTIFICATION CONCERNING PAYMENT OF PRESCRIBED FEES

(PCT Rules 12*bis*.1(b), 14, 15 and 16  
and Administrative Instructions,  
Sections 304, 323(b) and 707)

To:  
SUSHIL BHUDIA  
51 HONEYPOT LANE  
KINGSBURY  
MIDDLESEX  
LONDON  
NW9 9QN

Date of mailing  
(day/month/year) 20/11/2025

Applicant's or agent's file reference  
2510010

**PAYMENT DUE**  
see item 3 for time limits

International application No.  
PCT/GB2025/052528

International filing date/Date of receipt  
(day/month/year) 18/11/2025

Priority date (day/month/year)  
23/06/2025

Applicant **BHUDIA, SUSHIL**

1. The applicant is hereby notified that this receiving Office has received:

**the payment** of all the prescribed fees, and  **an overpayment**, which will be refunded in due course.

**no or insufficient payment** of the prescribed fees and the applicant is hereby **invited to pay the balance due**, as summarized under item 2, within the time limit(s) indicated under item 3.

2. **Fees and payment calculation:**

<u>£2,633.00</u>	<b>-</b>	<u>£0.00</u>	<b>=</b>	<u>£2,633.00</u>
Total fees payable		Amount paid		Balance

The details of the calculation are given in the Annex.

3. **Time limit(s) for payment and amount(s) payable (Rules 14.1, 15.3 and 16.1(f)):**

within ONE MONTH from the date of receipt of the international application (**for the transmittal fee** (if any), **the search fee** and **the international filing fee**). The amount payable for each fee is the amount applicable on the date of receipt of the international application.

within 16 MONTHS from the priority date (only for the fee for priority document). The applicant's attention is drawn to the fact that the request made by the applicant under Rule 17.1(b) will be considered not to have been made unless the fee is paid within that time limit.

4. Additional observations (if necessary):

The search copy will not be transmitted to the International Searching Authority until the search fee is paid (therefore the start of the international search will be delayed) (Rule 23.1(a) and (b)).

Name and mailing address of the receiving Office  
IPO  
Concept House, Cardiff Road, Newport, NP10 8QQ  
  
Facsimile No. Not Available

Authorized officer  
**Mathew Cox**  
  
Telephone No. +44 (0)1633 813947

**ANNEX TO FORM PCT/RO/102  
CALCULATION OF THE PRESCRIBED FEES**

*(If a reduced fee has been applied, the reduced amount is indicated.)*

International application No.  
**PCT/GB2025/052528**

**T Transmittal Fee**

Prescribed amount: . . . . .	£75.00	<input type="checkbox"/>	correct amount
Amount paid: . . . . .	£0.00	<input type="checkbox"/>	overpayment
Balance: . . . . .	£75.00	<input checked="" type="checkbox"/>	balance due

**S Search Fee**

Prescribed amount: . . . . .	£1,548.00	<input type="checkbox"/>	correct amount
Amount paid: . . . . .	£0.00	<input type="checkbox"/>	overpayment
Balance: . . . . .	£1,548.00	<input checked="" type="checkbox"/>	balance due

**I International Filing Fee**

Prescribed amount:

Fixed amount for first 30 sheets: . . . . . £1,189.00 i1

0 x £13.00 = £0.00 i2

Number of sheets      Fee per sheet  
in excess of 30

*(excluding pages referred  
to in Section 707(a-bis))*

Reduction where the international application is filed

*(See PCT Fee tables <http://www.wipo.int/pct/en/fees.pdf>):*

in electronic form, the request not being in  
character coded format . . . . . £179.00 r

or

in electronic form, the request being in character  
coded format . . . . . r

or

in electronic form, the request, description,  
claims and abstract being in character coded  
format . . . . . £0.00 r

Sub-total: . . . . . = £1,010.00 i1+i2-r

*Applicants from certain States are entitled to a reduction of 90% of the  
international filing fee. Where the applicant is (or all applicants are) so  
entitled, the total to be entered at I is 10% of the sub-total entered at  
(i1+i2-r); (see Notes to the Fee Calculation Sheet as annexed to the  
Request Form, PCT/RO/101, for details):*

	£1,010.00	<input type="checkbox"/>	correct amount
	£0.00	<input type="checkbox"/>	overpayment
Amount paid: . . . . .	£1,010.00	<input checked="" type="checkbox"/>	balance due
Balance: . . . . .			

**P Fee for Priority Document**

Prescribed amount: . . . . .	£0.00	<input type="checkbox"/>	correct amount
Amount paid: . . . . .	£0.00	<input type="checkbox"/>	overpayment
Balance: . . . . .	£0.00	<input type="checkbox"/>	balance due

**ES Fee for Earlier Search Documents**

Prescribed amount: . . . . .	£0.00	<input type="checkbox"/>	correct amount
Amount paid: . . . . .	£0.00	<input type="checkbox"/>	overpayment
Balance: . . . . .	£0.00	<input type="checkbox"/>	balance due

# PATENT COOPERATION TREATY

From the RECEIVING OFFICE

# PCT

NOTIFICATION OF THE INTERNATIONAL  
APPLICATION NUMBER AND OF THE  
INTERNATIONAL FILING DATE

(PCT Rule 20.2(c))

To: <b>SUSHIL BHUDIA</b> <b>51 HONEYPOT LANE</b> <b>KINGSBURY</b> <b>MIDDLESEX</b> <b>LONDON</b> <b>NW9 9QN</b>
---

Date of mailing <b>20/11/2025</b> <i>(day/month/year)</i>
--

Applicant's or agent's file reference <b>2510010</b>
---

**IMPORTANT NOTIFICATION**

International application No. <b>PCT/GB2025/052528</b>
---

International filing date <i>(day/month/year)</i> <b>18/11/2025</b>
--

Priority date <i>(day/month/year)</i> <b>23/06/2025</b>
--

Applicant <b>BHUDIA, SUSHIL</b>
---------------------------------

Title of the invention <b>A NORMAL KEY TURNED INTO A PAYMENT GATEWAY</b>
---

1. The applicant is hereby notified that the international application has been accorded the international application number and the international filing date indicated above.

2. The applicant is further notified that the record copy of the international application:

was transmitted to the International Bureau on 20/11/2025

has not yet been transmitted to the International Bureau for the reason indicated below and a copy of this notification has been sent to the International Bureau\*:

because the necessary national security clearance has not yet been obtained.

because *(reason to be specified)*:

\* The International Bureau monitors the transmittal of the record copy by the receiving Office and will notify the applicant (with Form PCT/IB/301) of its receipt. Should the record copy not have been received by the expiration of 14 months from the priority date, the International Bureau will notify the applicant (Rule 22.1(c)).

Name and mailing address of the receiving Office <b>IPO</b> <b>Concept House, Cardiff Road, Newport, NP10 8QQ</b>
Facsimile No. <b>Not Available</b>

Authorized officer <b>Mathew Cox</b>
Telephone No. <b>+44 (0)1633 813947</b>

# PATENT COOPERATION TREATY

From the RECEIVING OFFICE

# PCT

INVITATION TO CORRECT DEFECTS IN  
THE INTERNATIONAL APPLICATION

(PCT Articles 3(4)(i) and 14(1) and Rule 26)

To: <b>SUSHIL BHUDIA</b> 51 HONEYPOT LANE KINGSBURY MIDDLESEX LONDON NW9 9QN	Date of mailing <i>(day/month/year)</i> <b>20/11/2025</b>
Applicant's or agent's file reference <b>2510010</b>	<b>REPLY DUE</b> within <b>TWO MONTHS</b> from the above date of mailing
International application No. <b>PCT/GB2025/052528</b>	International filing date <i>(day/month/year)</i> <b>18/11/2025</b>
Applicant <b>BHUDIA, SUSHIL</b>	

1.  The applicant is hereby **invited**, within the time limit indicated above, to correct, **in the international application as filed**, the defects specified on the attached:

- Annex A
- Annex B1 (*text matter of the international application as filed*)
- Annex C1 (*drawings of the international application as filed*)

2.  The applicant is hereby **invited**, within the time limit indicated above, to correct, **in the translation of the international application** furnished under Rule 12.3 or 12.4, the defects specified on the attached:

- Annex A
- Annex B2 (*text matter of the translation of the international application*)
- Annex C2 (*drawings of the translation of the international application*)

**Additional observations (if necessary):**

**HOW TO CORRECT THE DEFECTS?**

Except where the defect is in the request, any correction must be submitted by filing a replacement sheet embodying the correction and a letter accompanying the replacement sheet, which shall draw attention to the difference between the replaced sheet and the replacement sheet. For a defect in the request, a correction may simply be stated in a letter if it is of such a nature that the correction can be transferred clearly onto the request record copy (Rule 26.4).

**ATTENTION**

Failure to correct the defects will result in the international application being considered withdrawn by this receiving Office (see Rule 26.5 for further details).

A copy of this Invitation and any attachments has been sent to the International Bureau

and the International Searching Authority.

Name and mailing address of the receiving Office IPO Concept House, Cardiff Road, Newport, NP10 8QQ	Authorized officer <b>Mathew Cox</b>
Facsimile No. Not Available	Telephone No. +44 (0)1633 813947

Form PCT/RO/106 (16 September 2012)

UK Intellectual Property Office is an operating name of the Patent Office

**The receiving Office has found the following defects in the international application as filed:**

1. As to the **signature** of the international application (Rules 4.15, 26.2bis(a) and 90.4), the request:
- is not signed by the applicant or, if there is more than one applicant, by at least one of them\*.
  - is signed by what appears to be an agent/common representative, but the international application is not accompanied by a power of attorney signed by at least one of the applicants\*.
  - other (*specify*):

\* The applicant's attention is drawn to the fact that the national law applied by each designated Office may require, in connection with the processing of the international application in the national phase, that the applicant furnish the confirmation of the international application by the signature of any applicant for the designated State who has not signed the request (Rule 51bis.1(a)(vi)).

2. As to the indications concerning the **applicant**\* who is entitled, according to Rule 19.1, to file the international application with the receiving Office, the request (Rules 4.4, 4.5 and 26.2bis(b)):
- does not properly indicate the applicant's name (*specify*):
  - does not indicate the applicant's address.
  - does not properly indicate the applicant's address (*specify*):
  - does not indicate the applicant's nationality.
  - does not indicate the applicant's residence.

Further observations about indications concerning other applicants (if applicable):

\* Although Rules 4.4 and 4.5 require indications concerning the applicant, or if there are several applicants, of each of them, for the purposes of Article 14(1)(a)(ii), if there is more than one applicant, it shall be sufficient that the indications required under Rule 4.5(a)(ii) and (iii) be provided in respect of one of them who is entitled according to Rule 19.1 to file the international application with the receiving Office (Rule 26.2bis(b)).

However, the applicant's attention is drawn to the fact that the national law applied by each designated Office may require, in connection with the processing of the international application in the national phase, that the applicant furnish any missing indication required under Rule 4.5(a)(ii) and (iii) in respect of any applicant for the designated State (Rule 51bis.1(a)(vii)).

3. As to the **language** of certain elements of the international application, other than the description and claims (Rules 12.1(c) and 26.3ter(a) and (c)):
- the **request** is not in a language of publication accepted by this receiving Office; (the language(s) accepted by this receiving Office is/are:
  - the **text matter of the drawings** is not in the language in which the international application is to be published, which is:
  - the **abstract** is not in the language in which the international application is to be published, which is:

4. The **title** of the invention:
- is not indicated in Box No. I of the request (Rule 4.1(a)).
  - is not indicated at the top of the first sheet of the description (Rule 5.1(a)).
  - as appearing in Box No. I of the request is not identical with the title heading the description (Rule 5.1(a)).

5. As to the **abstract** (Rules 8 and 26.1):
- the international application does not contain an abstract.

This receiving Office has found that, with regard to the presentation of the **text matter of the international application as filed**, the physical requirements are not complied with to the extent that compliance therewith is necessary for:

1.  reasonably uniform international publication (Rules 11 and 26.3(a)(i)) (*defects to be specified*):

	Request	Description	Claims	Abstract
a. <input type="checkbox"/> the sheets do not admit of direct reproduction	<input type="checkbox"/>	<input type="checkbox"/>	<input type="checkbox"/>	<input type="checkbox"/>
b. <input type="checkbox"/> the element does not commence on a new sheet	<input type="checkbox"/>	<input type="checkbox"/>	<input type="checkbox"/>	<input type="checkbox"/>
c. <input type="checkbox"/> sheets are not free from creases, cracks, folds	<input type="checkbox"/>	<input type="checkbox"/>	<input type="checkbox"/>	<input type="checkbox"/>
d. <input type="checkbox"/> sheets are not used in the upright position	<input type="checkbox"/>	<input type="checkbox"/>	<input type="checkbox"/>	<input type="checkbox"/>
e. <input type="checkbox"/> one side of the sheets is not left unused	<input type="checkbox"/>	<input type="checkbox"/>	<input type="checkbox"/>	<input type="checkbox"/>
f. <input type="checkbox"/> the paper of the sheets is not flexible/strong/white/smooth/non-shiny/durable	<input type="checkbox"/>	<input type="checkbox"/>	<input type="checkbox"/>	<input type="checkbox"/>
g. <input type="checkbox"/> the sheets are not connected as prescribed (Rule 11.4(b))	<input type="checkbox"/>	<input type="checkbox"/>	<input type="checkbox"/>	<input type="checkbox"/>
h. <input type="checkbox"/> sheets are not A4 size (29.7cm x 21cm)	<input type="checkbox"/>	<input type="checkbox"/>	<input type="checkbox"/>	<input type="checkbox"/>
i. <input type="checkbox"/> the minimum margins on the sheets are not as prescribed (top: 2cm; left side: 2.5cm; right side: 2cm; bottom: 2cm)		<input type="checkbox"/>	<input type="checkbox"/>	<input type="checkbox"/>
j. <input type="checkbox"/> the file reference number indicated on the sheets does not appear in the left-hand corner of the sheets, within 1.5 cm of the top of the sheets		<input type="checkbox"/>	<input type="checkbox"/>	<input type="checkbox"/>
k. <input type="checkbox"/> the file reference number exceeds the maximum of 12 characters	<input type="checkbox"/>	<input type="checkbox"/>	<input type="checkbox"/>	<input type="checkbox"/>
l. <input type="checkbox"/> the sheets of the description, claims and abstract are not numbered in consecutive Arabic numerals		<input type="checkbox"/>	<input type="checkbox"/>	<input type="checkbox"/>
m. <input type="checkbox"/> the sheet numbers are not centered at the top or bottom of the sheets	<input type="checkbox"/>	<input type="checkbox"/>	<input type="checkbox"/>	<input type="checkbox"/>
n. <input type="checkbox"/> the sheet numbers are in the margin (see i. above for the size of the margins)		<input type="checkbox"/>	<input type="checkbox"/>	<input type="checkbox"/>
o. <input type="checkbox"/> the text matter is not typed or printed	<input type="checkbox"/>	<input type="checkbox"/>	<input type="checkbox"/>	<input type="checkbox"/>
p. <input type="checkbox"/> the typing on the sheets is not 1½-spaced		<input type="checkbox"/>	<input type="checkbox"/>	<input type="checkbox"/>
q. <input type="checkbox"/> the characters in the text matter on the sheets are less than 0.28 cm high in capital letters	<input type="checkbox"/>	<input type="checkbox"/>	<input type="checkbox"/>	<input type="checkbox"/>
r. <input type="checkbox"/> the text matter on the sheets is not in dark, indelible color	<input type="checkbox"/>	<input type="checkbox"/>	<input type="checkbox"/>	<input type="checkbox"/>
s. <input type="checkbox"/> the element contains drawings	<input type="checkbox"/>	<input type="checkbox"/>	<input type="checkbox"/>	<input type="checkbox"/>
t. <input type="checkbox"/> the sheets contain alterations/overwritings/interlineations/too many erasures	<input type="checkbox"/>	<input type="checkbox"/>	<input type="checkbox"/>	<input type="checkbox"/>
u. <input type="checkbox"/> the sheets contain photocopy marks	<input type="checkbox"/>	<input type="checkbox"/>	<input type="checkbox"/>	<input type="checkbox"/>

2.  satisfactory reproduction (Rules 11 and 26.3(b)(i))

Further observations (*if necessary*):

This receiving Office has found that, with regard to the presentation of the **text matter of the translation of the international application**, the physical requirements are not complied with to the extent that compliance therewith is necessary for:

1.  reasonably uniform international publication (Rules 11 and 26.3b(ii)) (*defects to be specified*):

	Request	Description	Claims	Abstract
a. <input type="checkbox"/> the sheets do not admit of direct reproduction	<input type="checkbox"/>	<input type="checkbox"/>	<input type="checkbox"/>	<input type="checkbox"/>
b. <input type="checkbox"/> the element does not commence on a new sheet	<input type="checkbox"/>	<input type="checkbox"/>	<input type="checkbox"/>	<input type="checkbox"/>
c. <input type="checkbox"/> sheets are not free from creases, cracks, folds	<input type="checkbox"/>	<input type="checkbox"/>	<input type="checkbox"/>	<input type="checkbox"/>
d. <input type="checkbox"/> sheets are not used in the upright position	<input type="checkbox"/>	<input type="checkbox"/>	<input type="checkbox"/>	<input type="checkbox"/>
e. <input type="checkbox"/> one side of the sheets is not left unused	<input type="checkbox"/>	<input type="checkbox"/>	<input type="checkbox"/>	<input type="checkbox"/>
f. <input type="checkbox"/> the paper of the sheets is not flexible/strong/white/smooth/non-shiny/durable	<input type="checkbox"/>	<input type="checkbox"/>	<input type="checkbox"/>	<input type="checkbox"/>
g. <input type="checkbox"/> the sheets are not connected as prescribed (Rule 11.4(b))	<input type="checkbox"/>	<input type="checkbox"/>	<input type="checkbox"/>	<input type="checkbox"/>
h. <input type="checkbox"/> sheets are not A4 size (29.7cm x 21cm)	<input type="checkbox"/>	<input type="checkbox"/>	<input type="checkbox"/>	<input type="checkbox"/>
i. <input type="checkbox"/> the minimum margins on the sheets are not as prescribed (top: 2cm; left side: 2.5cm; right side: 2cm; bottom: 2cm)		<input type="checkbox"/>	<input type="checkbox"/>	<input type="checkbox"/>
j. <input type="checkbox"/> the file reference number indicated on the sheets does not appear in the left-hand corner of the sheets, within 1.5 cm of the top of the sheets		<input type="checkbox"/>	<input type="checkbox"/>	<input type="checkbox"/>
k. <input type="checkbox"/> the file reference number exceeds the maximum of 12 characters	<input type="checkbox"/>	<input type="checkbox"/>	<input type="checkbox"/>	<input type="checkbox"/>
l. <input type="checkbox"/> the sheets of the description, claims and abstract are not numbered in consecutive Arabic numerals		<input type="checkbox"/>	<input type="checkbox"/>	<input type="checkbox"/>
m. <input type="checkbox"/> the sheet numbers are not centered at the top or bottom of the sheets	<input type="checkbox"/>	<input type="checkbox"/>	<input type="checkbox"/>	<input type="checkbox"/>
n. <input type="checkbox"/> the sheet numbers are in the margin (see i. above for the size of the margins)		<input type="checkbox"/>	<input type="checkbox"/>	<input type="checkbox"/>
o. <input type="checkbox"/> the text matter is not typed or printed	<input type="checkbox"/>	<input type="checkbox"/>	<input type="checkbox"/>	<input type="checkbox"/>
p. <input type="checkbox"/> the typing on the sheets is not 1½-spaced		<input type="checkbox"/>	<input type="checkbox"/>	<input type="checkbox"/>
q. <input type="checkbox"/> the characters in the text matter on the sheets are less than 0.28 cm high in capital letters	<input type="checkbox"/>	<input type="checkbox"/>	<input type="checkbox"/>	<input type="checkbox"/>
r. <input type="checkbox"/> the text matter on the sheets is not in dark, indelible color	<input type="checkbox"/>	<input type="checkbox"/>	<input type="checkbox"/>	<input type="checkbox"/>
s. <input type="checkbox"/> the element contains drawings	<input type="checkbox"/>	<input type="checkbox"/>	<input type="checkbox"/>	<input type="checkbox"/>
t. <input type="checkbox"/> the sheets contain alterations/overwritings/interlineations/too many erasures	<input type="checkbox"/>	<input type="checkbox"/>	<input type="checkbox"/>	<input type="checkbox"/>
u. <input type="checkbox"/> the sheets contain photocopy marks	<input type="checkbox"/>	<input type="checkbox"/>	<input type="checkbox"/>	<input type="checkbox"/>

2.  satisfactory reproduction (Rules 11 and 26.3(a)(ii))

Further observations (*if necessary*):

This receiving Office has found that, with regard to the presentation of the **drawings of the international application as filed**, the physical requirements are not complied with to the extent that compliance therewith is necessary for:

1.  reasonably uniform international publication (Rules 11 and 26.3(a)(i)) (*defects to be specified*):

**Sheets containing drawings:**

- a.  the sheets do not admit of direct reproduction
- b.  the sheets are not free from creases, cracks, folds
- c.  one side of the sheets is not left unused
- d.  the paper of the sheets is not flexible/strong/white/smooth/non-shiny/durable
- e.  the drawings do not commence on a new sheet
- f.  the sheets are not connected as prescribed (Rule 11.4(b))
- g.  the sheets are not A4 size (29.7cm x 21cm)
- h.  the minimum margins on the sheets are not as prescribed (top: 2.5cm; left side: 2.5cm; right side: 1.5cm; bottom: 1cm)
- i.  the file reference number indicated on the sheets does not appear in the left-hand corner of the sheets, within 1.5 cm of the top of the sheets
- j.  the file reference number exceeds the maximum of 12 characters
- k.  the sheets are not free from frames around usable or used surfaces
- l.  the sheets are not numbered in consecutive Arabic numerals (e.g. 1/3, 2/3, 3/3)
- m.  the sheet numbers are not centered at the top or bottom of the sheets
- n.  the sheet numbers are in the margin (see h. above for the size of the margins)
- o.  the sheets contain alterations/overwritings/interlineations/too many erasures
- p.  the sheets contain photocopy marks

**Drawings (Rule 11.13):**

- a.  do not admit of direct reproduction
- b.  contain unnecessary text matter
- c.  contain words so placed as to prevent translation without interference with lines thereof
- d.  are not executed in durable black color; the lines are not uniformly thick and well-defined
- e.  contain cross-sections not properly hatched
- f.  would not be properly distinguishable in reduced reproduction
- g.  contain scales not represented graphically
- h.  contain numbers, letters and reference lines lacking simplicity and clarity
- i.  contain lines drafted without the aid of drafting instruments
- j.  contain disproportionate elements of a figure not necessary for clarity
- k.  contain numbers and letters of height less than 0.32 cm
- l.  contain letters not conforming to the Latin, and where customary, Greek alphabets
- m.  contain figures on two or more sheets which form a single complete figure but which are not able to be assembled without concealing parts thereof
- n.  contain figures which are not properly arranged and clearly separated
- o.  contain different figures not numbered in consecutive Arabic numerals
- p.  contain different figures not numbered independently of the numbering of the sheets
- q.  are not restricted to reference signs mentioned in the description
- r.  do not contain reference signs that are mentioned in the description
- s.  contain the same feature denoted by different reference signs
- t.  are not arranged in an upright position, clearly separated from one another
- u.  are not presented sideways with the top of the figures at the left side of the sheets

2.  satisfactory reproduction (Rules 11 and 26.3(b)(i))

Further observations (*if necessary*):

This receiving Office has found that, with regard to the **drawings of the translation** of the international application, the physical requirements are not complied with to the extent that compliance therewith is necessary for:

1.  reasonably uniform international publication (Rules 11 and 26.3(b)(ii)) (*defects to be specified*):

**Sheets containing drawings:**

- a.  the sheets do not admit of direct reproduction
- b.  the sheets are not free from creases, cracks, folds
- c.  one side of the sheets is not left unused
- d.  the paper of the sheets is not flexible/strong/white/smooth/non-shiny/durable
- e.  the drawings do not commence on a new sheet
- f.  the sheets are not connected as prescribed (Rule 11.4(b))
- g.  the sheets are not A4 size (29.7cm x 21cm)
- h.  the minimum margins on the sheets are not as prescribed (top: 2.5cm; left side: 2.5cm; right side: 1.5cm; bottom: 1cm)
- i.  the file reference number indicated on the sheets does not appear in the left-hand corner of the sheets, within 1.5 cm of the top of the sheets
- j.  the file reference number exceeds the maximum of 12 characters
- k.  the sheets are not free from frames around usable or used surfaces
- l.  the sheets are not numbered in consecutive Arabic numerals (e.g. 1/3, 2/3, 3/3)
- m.  the sheet numbers are not centered at the top or bottom of the sheets
- n.  the sheet numbers are in the margin (see h. above for the size of the margins)
- o.  the sheets contain alterations/overwritings/interlineations/too many erasures
- p.  the sheets contain photocopy marks

**Drawings** (Rule 11.13):

- a.  do not admit of direct reproduction
- b.  contain unnecessary text matter
- c.  contain words so placed as to prevent translation without interference with lines thereof
- d.  are not executed in durable black color; the lines are not uniformly thick and well-defined
- e.  contain cross-sections not properly hatched
- f.  would not be properly distinguishable in reduced reproduction
- g.  contain scales not represented graphically
- h.  contain numbers, letters and reference lines lacking simplicity and clarity
- i.  contain lines drafted without the aid of drafting instruments
- j.  contain disproportionate elements of a figure not necessary for clarity
- k.  contain numbers and letters of height less than 0.32 cm
- l.  contain letters not conforming to the Latin, and where customary, Greek alphabets
- m.  contain figures on two or more sheets which form a single complete figure but which are not able to be assembled without concealing parts thereof
- n.  contain figures which are not properly arranged and clearly separated
- o.  contain different figures not numbered in consecutive Arabic numerals
- p.  contain different figures not numbered independently of the numbering of the sheets
- q.  are not restricted to reference signs mentioned in the description
- r.  do not contain reference signs that are mentioned in the description
- s.  contain the same feature denoted by different reference signs
- t.  are not arranged in an upright position, clearly separated from one another
- u.  are not presented sideways with the top of the figures at the left side of the sheets

2.  satisfactory reproduction (Rules 11 and 26.3(a)(ii))

Further observations (*if necessary*):

# **PAY BY KEY**

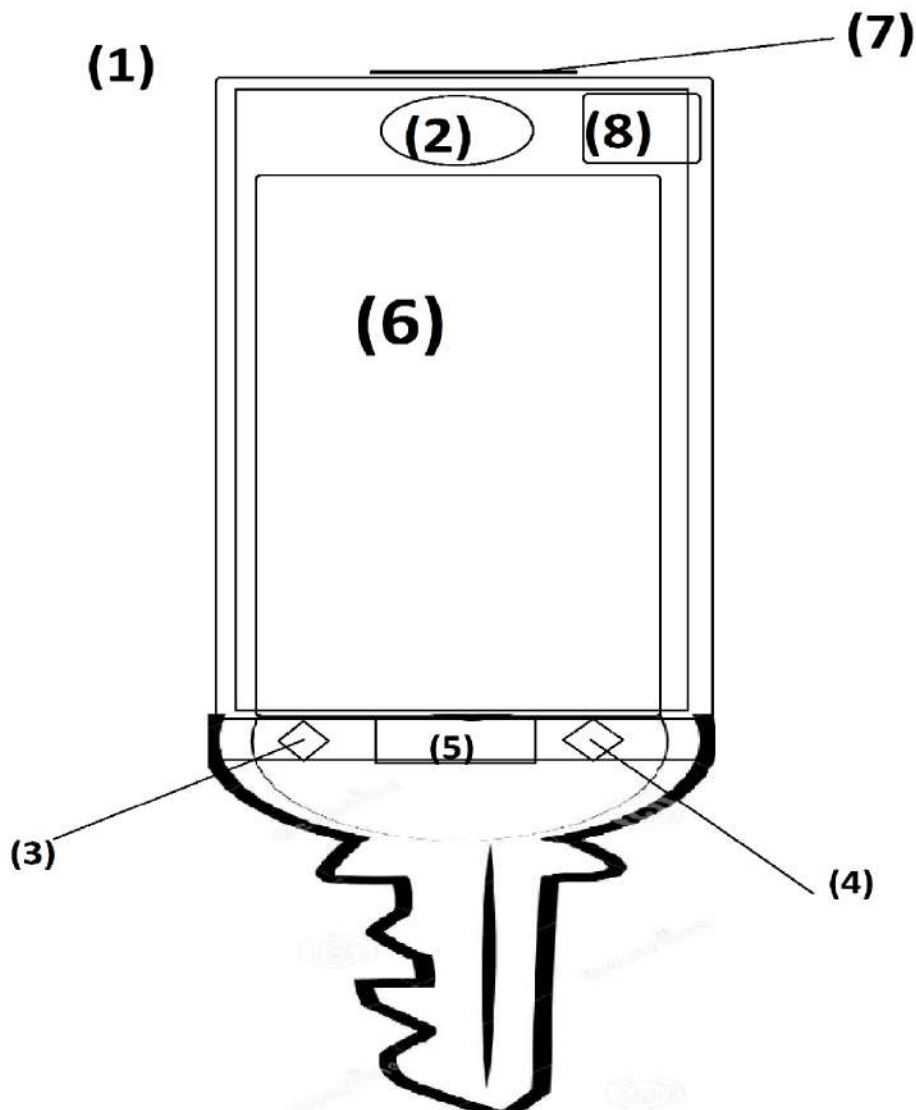

## **KEY:**

- (1) DIGITAL PCB INBETWEEN THE CASE**
- (2) OPTICAL LENS CAMERA**
- (3) PAYMENT SENSORS (DEBIT ON ACCOUNT)**
- (4) PAYMENT SENSORS (CREDIT ON ACCOUNT)**
- (5) SWAB FACILITY SENSOR WITH PAYMENT GATEWAY**
- (6) TOUCH LCD WHICH SHOWS ACCOUNT BALANCE /MESSAGING**
- (7) CONTACT ASSEMBLIES ALLOWING FOR DOCKING ON KEYBOARD**
- (8) AUDIO PORT FOR MUSIC ETC.**

# PAY BY KEY WITH NETWORKS

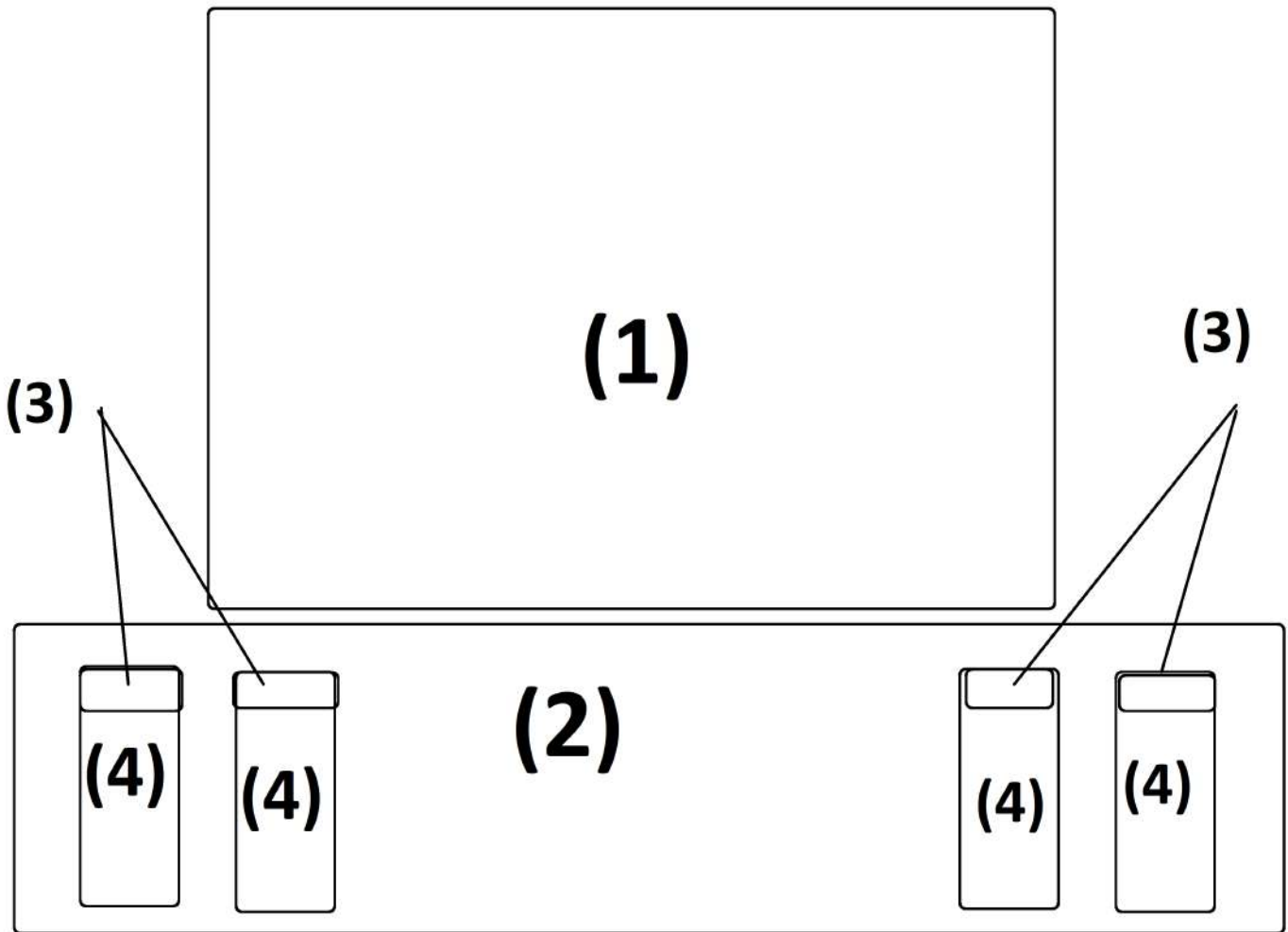

**KEY:**

**(1) TFT MONITOR SCREEN (UPPER TFT LCD)**

**(2) KEYBOARD**

**(3) KEY CONTACT ASSEMBLIES**

**(4) x 4 PAY BY KEY NETWORKS**

## OPTIMUM EFFICIENT

Well as you have seen by some of the designs it reduces Service Costs and uses ultra optimum efficient service and spare part chains and solutions.

The service facility becomes efficient and does not hold too much stock unnecessary.

The components in this venture are limited and do not need a large holding inventory.

Perfect for customer after sales support.

This system periodically emphasises the use of the keyboard and the redesign of it.

All items can be built in to the keyboard such as kettle, printer, razor etc with the use of contact assemblies on the base of the set.

Even TV's can tun into computers.

The Computer Key can use lithium and solar and motion technology to charge the product.

Key pay can use radio and you tube to optimize the key set built into the key at factory level newly set.

There is derived demand in my "Key Pay", in such that glasses or spectacles can be used to make payment method, writing pens (PEN PAY) can be used to make payment. Also Headphones can be used to make payment for goods and services.

To be true money supply becomes limited and there are less crime and less counter fit money circulating in the economy.

Why not use lipsticks or eyelash curls to make payments or even nail varnish?

Its an option I guess but never been tried.

Mobile Payment systems are thing of the past know, I feel KEY PAY is the most advance and most fastest payment to conceptualise.



Mr Sushil Karsan Bhudia, DIGITAL CAMERA REPAIRS & GRAPHIC DESIGN CENTRE, Euro Hi-Tech Photographic Services Ltd, 51 HONEYPOT LANE, KINGSBURY, HARROW, GREATER LONDON, LONDON, MIDDLESEX, ENG, UK NW9 9QN. [sushil@eurohitech.com](mailto:sushil@eurohitech.com).

M: 07915382908

## **NO USB & NO CABLE MATHS FORMULA**

NO USB /NO CABLE= 2 (PIN SET ON  
KEYBOARD (DSLR MIRROR BOX SIDE))  
+ 2 (FLAT CONTACTS ON HAND SET  
(REAR MOUNT CONTACTS LENS SIDE))  
+ RELEASE MECHANISM ON  
KEYBOARD

*Where NO USB =  $(2+ n)$  or  $2n$  Squared as  $N$  Approaches infinity*

*COPY RIGHT*

MULTI TOOTH BRUSH AND RAZOR/SHAVER 2 IN 1 BY EURO HI-TECH PHOTOGRAPHIC SERVICES LTD,  
MR SUSHIL BHUDIA-GB2611652.5 FILE DATE: 19-5-26

#### **DESCRIPTION**

This is a toothbrush combined with a men's shaver or unisex razor on one handle.

This example can be computerised with a built in LCD which displays power in the unit, it also has an audio port to listen to music whilst brushing or shaving.

It consists of a speaker and a microphone where you can connect to WIFI built in and use as a telecom for speaking to anyone via telephone through the 2 in 1 system.

It powers up two ways one with a USB port, or alternatively via SLR/DSLR Camera Contact Assemblies on the exemplified unit which docks in to the Key board.

This then use vibrations from the keyboard to charge the unit. Also, a solar power finish with motion detection will be built in the unit, therefore allowing electronic brushing and shaving, streamline.

The unit had a foldable brush and foldable razor or shaver arm which folds or flips in to the centre base unit. With two release units to release the brush or the razer shaver.

It can be made of various common material and digitised by the Main PCB in the central base unit.

The main PCB also allows you to make payment with this 2 in 1 device and acts as a gate way.

This unit allows you to see the payments on the LCD via the credits and debits on account.

PORTABLE 2 IN 1 RAZER AND TOOTH BRUSH

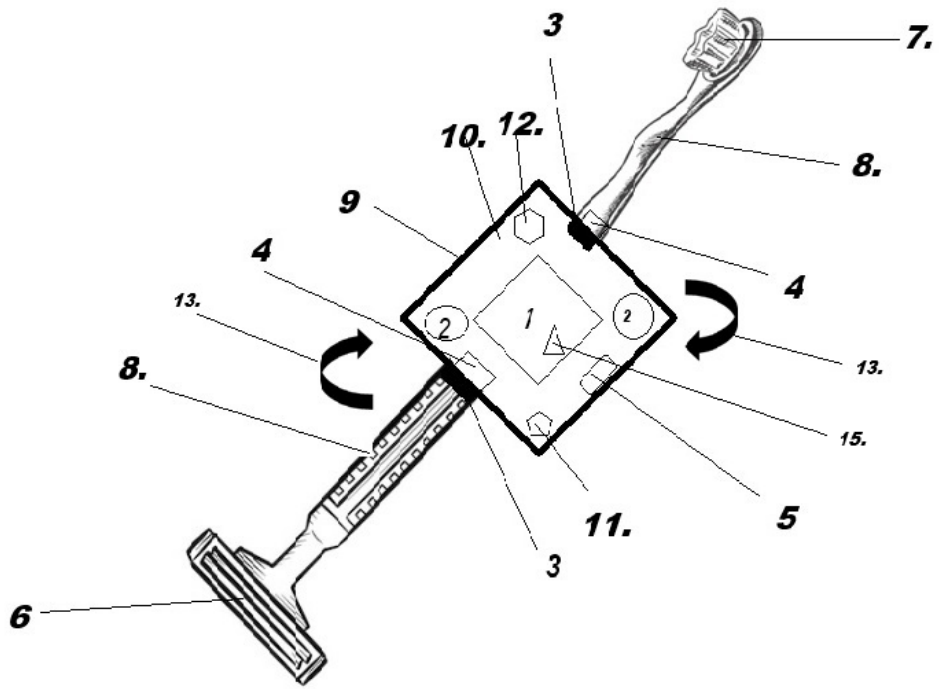

KEY:

1. LCD TO CONNECT TO TELECOM MAKE CALLS AND MESSAGING
2. RELEASE UNIT BUTTONS
3. HINGE TO ROTATE BRUSH AND RAZER INTO CENTRAL PORTABLE COMPACT BASE
4. OPTION OF SLR DSLR CONTACT ASSY FOR CHARGING AND DISPLAYING SOFTWARE DOCKED ON KEYBOARD WITH NO CABLES AND DISPLAYED WITH SOFTWARE.
5. OPTION OF USB CHARGING
6. RAZER OR SHAVER
7. TOOTHBRUSH /OR ELECTRONIC TOOTHBRUSH
8. HANDLE /GRIP
9. COMPACT CENTRAL BASE UNIT
10. MAIN PCB WITH WI FI OR BLUE TOOTH-PAYMENT GATEWAY
11. AUDIO PORT TO LISTEN TO MUSIC
12. SPEAKER
13. FOLDABLE HANDLE OR FLIP OF HANDLE OR GRIP IN TO THE CENTRAL BASE UNIT/COMPACT BASE UNIT. 180 Degree Rotation. (FLIP MODE)
14. INFRA RED TO MAKE PAYMENTS FOR GOODS AND SERVICES AND BLUETOOTH.
15. CAMERA/OPTICS

**SLIM LIME CENTRAL PORTABLE BASE  
UNIT FOLDABLE BRUSH AND RAZER  
SHAVER**

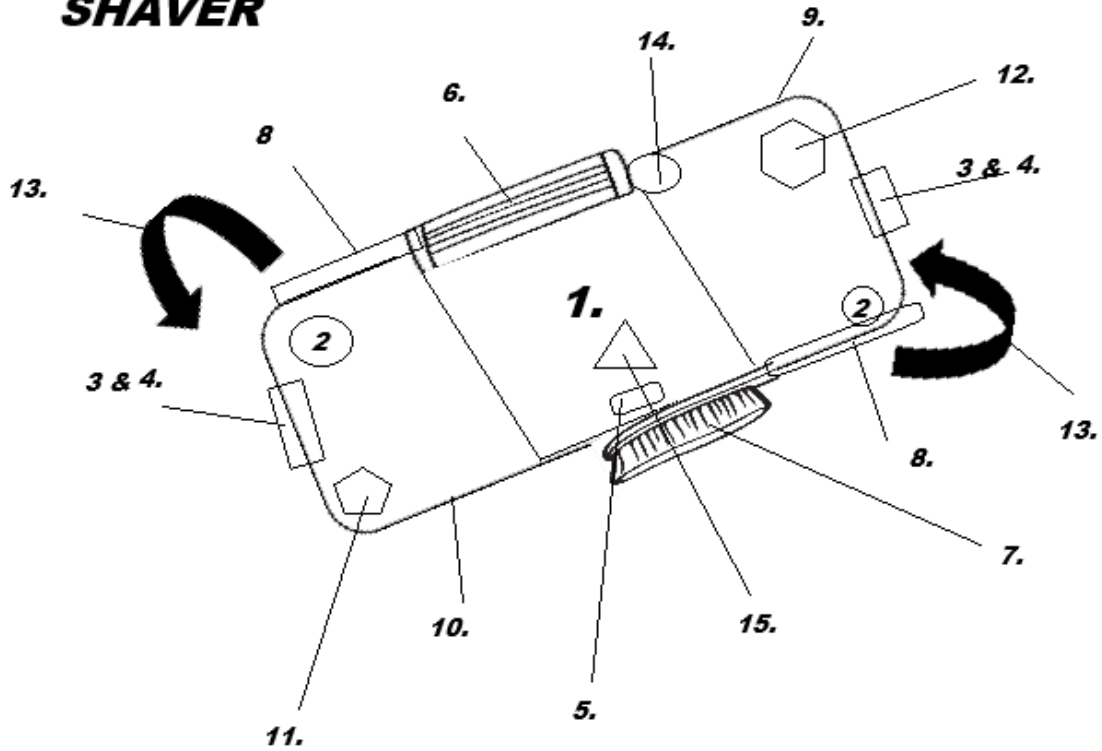

KEY:

1. LCD TO CONNECT TO TELECOM MAKE CALLS AND MESSAGING
2. RELEASE UNIT BUTTONS
3. HINGE TO ROTATE BRUSH AND RAZER INTO CENTRAL PORTABLE COMPACT BASE
4. OPTION OF SLR DSLR CONTACT ASSY FOR CHARGING AND DISPLAYING SOFTWARE DOCKED ON KEYBOARD WITH NO CABLES AND DISPLAYED WITH SOFTWARE.
5. OPTION OF USB CHARGING
6. RAZER OR SHAVER
7. TOOTHBRUSH /OR ELECTRONIC TOOTHBRUSH
8. HANDLE /GRIP
9. COMPACT CENTRAL BASE UNIT
10. MAIN PCB WITH WI FI OR BLUE TOOTH-PAYMENT GATEWAY
11. AUDIO PORT TO LISTEN TO MUSIC
12. SPEAKER
13. FOLDABLE HANDLE OR FLIP OF HANDLE OR GRIP IN TO THE CENTRAL BASE UNIT/COMPACT BASE UNIT. 180 Degree Rotation. (FLIP MODE)
14. INFRA RED TO MAKE PAYMENTS FOR GOODS AND SERVICES AND BLUETOOTH.
15. OPTICS CAMERA

## CLAIMS

I am here by claiming that the solution to combine two handles i.e one for the razer and one for the brush is now combined in to 1 one handle. Both operate at opposite ends of the handle.

The tooth brush and razer or shaver is combined in to 2 in 1 solution, here by saving factory costs and material costs in the R&D.

You can also add a tongue cleaner to this brush, at the opposite where the bristles are.

I claim that the mechanics of the central base unit is computerised with an LCD Panel for battery power and credit and debits of a payment gateway. The infra-red can be used to make payment for goods and services and credits of cash can be debited in to a Post Office or Confectionary store.

Both ends of the handle can fold/flip in o the central base as exemplified by the diagrams to keep it compact. They then can be released by a release mechanism depending if you want to use the brush or shaver or both at the same time.

There is wifi and blue tooth and an audio port when you can send and receive message via the microphone /WIFI and listen to music via premium you tube via the speaker.

You can also take pictures of the cavity by the button built into the LCD via the camera.

There are options for power.

Once is a direct USB Connection with a cable.

The other is the use of ancient SLR DSLR Technology of contact assemblies, this docks the above unit into the keyboard and charges via vibrations and motion and solar panel finish.

There are no cables here in the Use of keyboard docking. This theory is outlined in PAY BY KEY GB2510010.8 AND COMPUTER FILES GB2510034.8.

The razer and toothbrush are built in such a way they fold in o the central base unit, flush.

The blade can be removed and reattached if required for health and safety.

You can also combine a KEY to the central base unit like the ones to open and close doors in cars houses office etc.

So to summarise this device combines the razer and tooth brush on one handle, at each ends. Which then be flipped or folded in to a portable payment gateway into a central base unit.

## ABSTRACT

Again to summarise, this is the use of a toothbrush with bristles and a tongue cleaner at one end of the handle, and a razer/shaver at the other end of the handle. *They both combine into one handle.* They then fold into a slim line central base mechanism as shown in the second diagram. And can be released when required to use.

This can be charged by a USB Port in the sort run, and SLR/DSLR Technology of contact assemblies in the long run. So for the latter there is no cable and docks in to the Keyboard and charges by solar motion and vibration.

The MAIN PCB is shock and water splash proof and runs the operating system to allow for messaging, audio, landline phone and payment gateway, to credit and debit the device Banking Account sync by the mobile.

The infra red can allow to make payment on the ISBN BAR CODE so shop pay and go with a tooth brush or shaver.

This reduces waste and is long lasting. It cuts factory cost and is innovation if you look naturally.

It is unique and can watch videos on the LCD of the slim line central base unit.